



SANTA FE COUNTY
SUSTAINABILITY

SANTA FE COUNTY GREEN STORMWATER INFRASTRUCTURE

LOW IMPACT DESIGN STRATEGIES FOR DESERT COMMUNITIES



ACKNOWLEDGEMENTS

We would like to thank the people of the Tewa, Keres, and Zuni Pueblos, as well as the other Indigenous peoples of the American Southwest region, for their wisdom in developing the sustainable land stewardship practices that many of the erosion mitigation, water harvesting, and water conservation techniques included in this GSI manual are based upon. It is of the utmost importance that we return to and honor the wisdom in these ecological traditions to better care for both the land and water that make up what we now call Santa Fe County, which has been cared for and known as Oga Po'geh ("White Shell Water Place") by the Tewa people for thousands of years.

Santa Fe County honors that Lake Peak, the Santa Fe River, the Rio Grande, and the entire watershed of this region have been and continue to be the sacred waters and homeland of many Indigenous peoples, long before we have called them by their colonial names. Santa Fe County recognizes that its boundaries make up but a portion of a larger, contiguous swath of land that contains a complex, layered, and diverse history, as well as an intimate, ancestral significance for the many Indigenous peoples who have resided here, both historically and presently. The Santa Fe River Watershed, which extends beyond the boundaries of Santa Fe County, shares a relationship with the Tewa, Towa, Tiwa, and Keres Pueblos, as well as the Apache, Diné, Ute, and Comanche peoples. Within its boundaries are the homelands of seven sovereign Pueblo nations, whose wellbeing Santa Fe County is committed to serving and advancing. These Pueblos traditionally speak either the Keres or Tewa languages and include the Santa Clara Pueblo, the San Ildefonso Pueblo, the Pojoaque Pueblo, the Nambé Pueblo, the Tesuque Pueblo, the Cochiti Pueblo, and the Santo Domingo (Kewa) Pueblo.

ACKNOWLEDGEMENTS

Special thanks for the many contributions and efforts to make this important guide come to fruition by the county's community development department, public works, growth management, and the county manager's office departments, to include commissioners in office from 2024–2026. Without the vital teamwork, expertise, and striving of staff for effective and healthier water resource management in the Santa Fe County's uniquely arid and fragile ecosystem environment, none of the following would be possible.

- Santa Fe County Sustainability Office

© APRIL 2026



Scan this QR code to learn more about Santa Fe County's 4Nature initiative.

To access a digital version of this guide, click the link that says "Download Guide" in the banner to the right of the 4Nature landing page.



ACKNOWLEDGEMENTS

SANTA FE COUNTY AND THE OFFICE OF SUSTAINABILITY

Gregory S. Shaffer, Santa Fe County Manager

Leandro Cordova, Deputy County Manager

Jonathan Butler, Community Development Department Director

Brian Snyder, Public Works Department Director

Jacqueline Beam, Sustainability Manager

Will Donahoo, Sustainability Specialist

Elizabeth Houghton, Sustainability Specialist

Michael Carr, Environmental Compliance Officer

Phillip Montano, Facilities and Project Division Director

Laura Hernandez, Facility OPS Maintenance Manager

Len Bundra, GIS Manager

Pratisha Sharma, GIS Analyst

Boleslo Romero, GIS Team Leader

Christopher Vaisa, Database Administrator

Alexandra Ladd, Growth Management Director

Paul Olafson, Former Community Development Department Director

SANTA FE COUNTY COMMISSIONERS

Anna Hansen

Adam F. Johnson

Anna Hamilton

Camilla Bustamante

Hank Hughes

Lisa Cacari Stone

Justin S. Greene

THIS DOCUMENT DEVELOPED FOR SANTA FE COUNTY BY THE RAINCATCHER INC AND SOUTHWEST URBAN HYDROLOGY LLC.

Narrative – Aaron Kauffman, Southwest Urban Hydrology LLC

GSI Deep Dives – Reese Baker, The Raincatcher Inc

Graphics and Layout – Linne Lalire, Breck Bowen, Dani Mosher, Shasta Woodfin, The Raincatcher Inc

Design – Linne Lalire, Breck Bowen, Shasta Woodfin, The Raincatcher Inc

Editor – The Raincatcher Inc. Team

Photos – Aaron Kauffman, Reese Baker, Esha Chiocchio, Linne Lalire, Breck Bowen, David Woodfin

Horticultural Consultant – Tracy Neal

Special thanks to The Raincatcher Inc. installation and maintenance crews, whose work is featured in this manual.

In addition, we would like to thank the following people for their contributions to pioneering the many facets of GSI in both rural and urban environments in the Southwest. Their continued support, dedication, experience, and knowledge has made this movement possible.

Brad Lancaster, Author of Rainwater Harvesting for Drylands and Beyond.

Rich Schrader, River Source, Inc.

Jeremiah Kidd, San Isidro Permaculture, Inc.

Zoe Isaacson, City of Santa Fe River and Watershed Manager

Mori Hensley, Executive Director, Santa Fe Watershed Association

Craig Sponholtz, Watershed Artisans Inc.

Bill Zeedyk, Zeedyk Ecological Consulting, LLC

Steve Carson, Rangeland Hands, Inc.

TABLE OF CONTENTS

INTRODUCTION	04-06	GSI COMPONENTS (CONTINUED)	
STORMWATER POLLUTANTS	07-09	Runoff from Rooftops	52-53
GSI FEATURES	10-11	Pumice Wick	54-55
Bio-retention Basin	12-15	Runoff from Impervious Surfaces	56-57
Bio-swale	16-19	Permeable Pavement	60-63
Bump-out/Chicane	20-23	Deflector or Drain Caps	64-69
Parking Space Retrofit	24-27	Inlets	70-73
Rain Garden	28-31	Basin Border	74-79
GSI DEEP DIVE		Urban Zuni Bowl Modification	80-81
Human Health	32-33	Sediment Traps	82-85
Urban Hydrology	41	Weirs/Outlets/Ponding Depth	86-91
Urban Stormwater Quality	60-61	Soils	92-97
Mycoremediation	98-99	Vegetation	100-101
Urban Forestry	108	Myco-Sponge	102-105
Phytoremediation	109	Plant Installation Guide	106-107
GSI COMPONENTS	34-37	PLANT LIST	110-121
Area of Runoff	38-40	MAINTENANCE	122-123
Runoff from Disturbed Soils	42-43	WILDFIRE DEFENSIBLE SPACE	124-127
Media Luna	44-45	DEFINITIONS	128
One Rock Dam	46-47	REFERENCES AND RESOURCES	129-133
Rock Rundown	48-49		
Zuni Bowl	50-51		

INTRODUCTION

THE IMPORTANCE OF WATER

While driving around northern New Mexico it's not uncommon to see a bumper sticker stating "El agua es vida." The phrase "Water is life" is a common refrain that touches on the fundamental understanding that water is essential for life. This knowledge not only precipitates through agricultural traditions aimed at maintaining and utilizing acequias for irrigation, but also in codes, ordinances, policies, and other daily activities focused on better management of water resources.

Communities around Santa Fe County have been at the forefront of a movement to conserve water and protect watersheds through initiatives aimed at replacing and upgrading indoor plumbing fixtures, offering rebates for or requiring roof water catchment cisterns, resting and replenishing aquifers by transitioning to surface water resources, promoting the use of more drought-tolerant vegetation and efficient irrigation systems for landscaping, etc.

The result has been per capita water usage far below other semiarid communities in the region. There are still major gains in water saving to be made, however, including better management of stormwater runoff through Green Stormwater Infrastructure (GSI) and other Best Management Practices (BMPs).



WHAT IS GSI ?

GSI is a method of utilizing small basins, soil, plants, and other natural systems for the purpose of passively capturing, infiltrating, and treating stormwater runoff close to where it falls as precipitation. By mimicking natural hydrological processes, GSI poses a more sustainable and cost-effective solution to managing stormwater than conventional, centralized grey infrastructure systems by storing water in dispersed, living systems that beautify their surroundings. GSI is not a new concept, but much of the existing scientific literature and designs relating to it originate from wetter climates. At times, implementation of non-regionally specific GSI in arid climates has resulted in failed projects, sometimes costing tens of thousands of dollars. The omission of a component as simple as a sediment trap can render GSI projects in the Southwest useless after a couple of storms.

A paradigm shift that results in widespread adoption of GSI around Santa Fe County requires designs that have been installed, evaluated, and refined to meet the challenges unique to the region's climate, water resources, and other local factors.

PURPOSE

Santa Fe County and its partners involved in the development of this manual have been at the forefront of building, assessing, and adapting GSI around northern New Mexico that acknowledges these regional specificities. Their work has resulted in GSI that not only meets the basic objectives of stormwater infiltration, but also recognizes the nuances that influence maintenance requirements, reimagines landscape aesthetics, improves

biodiversity, leads to community education, and most importantly: functions.

The intention of this manual is to present the necessary components to design GSI and other BMP features aimed at slowing, infiltrating, and treating stormwater runoff in urban and rural areas. The following designs have been tested, refined, and adapted for optimal performance in this climate. Concerns and points of failure are also noted to help guide engineers, designers, planners, and other practitioners with elements that might be less commonly understood or utilized in local development.

HOW TO USE THIS MANUAL

This guide will begin by reviewing concerns related to disturbances to watershed functions including common pollutants and conventional stormwater mitigation practices. The manual will then introduce GSI features and other BMPs (e.g. rain gardens, bioretention basins, etc.), systems that can be implemented into new and existing infrastructure or degraded landscapes to better manage the flow of stormwater through them and mitigate erosion. Following the introduction of the GSI features, the manual will break down the essential components needed for their design with construction diagrams/details and notes, which should be consulted and adapted to the specific needs and dimensions of your site to ensure that the GSI features are installed and functioning correctly. Stormwater measurement calculations, regionally appropriate plant lists, links, citations, and other resources for further reading can also be found throughout the guide.



There will be 4Nature icons included throughout the manual that reference categories of sustainable initiatives Santa Fe County is working towards. To learn more, scan the QR code on page 1.



Figure 1. The major watersheds of Santa Fe County.

The organization of this manual can be thought of as a cookbook in which the GSI “features” are the recipes and the GSI “components” are the ingredients, whose preparation must be understood in order to properly execute the “recipe.”

It is recommended that readers first flip through the manual to get an understanding of the possibilities at their disposal, then return to study certain sections and diagrams in more depth once they have developed an understanding of how the various aspects of GSI interact and which types of GSI interventions are applicable to their site or project.

CONTEXT

Santa Fe County, located in north central New Mexico, encompasses 1,910 square miles and has a population of about 157,000 people (1). Surface water only comprises 0.08 percent of the County’s area, but its varying topography contributes runoff that supports unique and vital watersheds (Figure 1).

Some of the watersheds include the entirety or parts of the Santa Fe, Tesuque, Galisteo, Santa Cruz, Nambe, Chiquito, and other rivers. These smaller watersheds support the Upper/Middle Rio Grande Valley, Estancia, and Pecos River basins.

As the population in Santa Fe County has shifted in size and extent, soil conditions have been altered. Whether in rural or more densely populated areas, changes to soil fertility, infiltration rates, and vegetation cover can result in negative impacts to watershed hydrology including water quality and quantity. Examples of land management that can affect stormwater runoff, water quality, and other environmental factors are shown in Figure 2.

INTRODUCTION

GRAZING:

Livestock, including cattle and sheep, have a long history in Santa Fe County, particularly with the arrival of the railroad in the late 1800s. While livestock can be a critical part of rural culture and economies, if poorly managed they can also contribute to overgrazing and compacted soils. Denuded soil cover with reduced permeability can lead to a transition from the uniform displacement of soil as sheet erosion into more rapid and problematic stormwater runoff and erosion features such as rills and gullies. Widespread arroyo formation and the desiccation of pastures in northern New Mexico rangelands during the early 1900s can be largely attributed to poor grazing management.

FIRE:

Santa Fe County falls within rich and diverse ecosystems such as grasslands, pinon-juniper savannas and woodlands, and various forest types such as ponderosa, mixed-conifer, and alpine. Each of these ecosystems have unique fire regimes which have been altered through fire suppression, logging,

and grazing practices. In some instances, the changes to fuels have left areas vulnerable to high intensity fires that can have severe consequences such as vegetative cover loss and water repellent soils. In turn, this can lead to stormwater problems such as flooding, erosion, poor water quality, etc.

AGRICULTURE:

Plowing, mowing, and other agricultural practices often rely on heavy machinery which can reduce soil structure. Structure is an important soil characteristic that is descriptive of how soil aggregates are held together; usually by the decomposition of organic material which forms topsoil. Healthy topsoil typically has good porosity, infiltration, and fertility. Negative impacts on soil structure can result in slower infiltration rates and increased runoff, erosion, and diminished soil nutrients needed for plant recovery.

ROADS & PARKING LOTS:

A basic principle behind creating safe driving conditions is to establish dry impervious surfaces. This requires roads to rapidly drain stormwater to the

surface periphery. Stormwater displaced from these surfaces can be laden with unique pollutants (e.g. heavy metals, petroleum products, and sediment) which are often discharged from pipes or ditches into flood-prone and erodible channels (e.g. arroyos, streams). These impervious surfaces also tend to retain heat which can lead to urban heat islands (UHI) in more densely populated areas.

ROOFTOPS:

Whether residential or commercial, flat or pitched, rooftops not only prevent precipitation from entering a building, but in many cases direct stormwater away from the foundation and off site. This practice is counterproductive in semiarid regions considering buildings are often recipients of distant water resources needed for indoor use and exterior irrigation. Stormwater runoff from rooftops is one of the easiest water resources to capture and utilize in active or passive irrigation systems due to reliably calculated surface areas, minimal sediment, and elevated surfaces that can utilize gravity for conveyance.



Figure 2. Disturbances to soil including overgrazing (left), fire (middle), and impervious development (right) can lead to excess stormwater runoff and erosion.

STORMWATER POLLUTANTS

GREY INFRASTRUCTURE

There are numerous conventional methods used to mitigate the consequences of stormwater runoff and associated erosion on the landscape and in channels. Armoring of arroyos and rivers with gabions, concrete weirs, or widespread concrete lining have been tried to reduce erosion and define channel dimensions. The response to flooding on streets and parking lots usually includes the implementation of larger culverts and pipes, bigger storm drains, and massive detention basins. Many of these methods of stormwater management would fall under a description of grey infrastructure (i.e. highly engineered materials and structures that rely on “grey” concrete, asphalt, metals, etc.). While these structures work in certain situations to improve driving

conditions and protect utilities, there are drawbacks. Limitations include a failure to address the origin of the problems, particularly disturbances to soil permeability. In essence, grey infrastructure often moves a problem downslope by concentrating stormwater into straighter and larger conveyance systems, which effectively dries out areas where precipitation falls (i.e. desertification) and sends water resources downslope; often in the form of flooding. Grey infrastructure also commonly fails to address stormwater pollutants, is expensive to implement, can be energy intensive and resource extractive (e.g. pumps to move water, petroleum to seal asphalt, etc.), offers minimal aesthetic appeal, compromises habitat, displaces wildlife, and contributes to urban heat island effect.

STORMWATER POLLUTANTS

In addition to the negative impacts of impervious development on runoff quantities, there are also unique and problematic pollutants that collect on its surface and are carried away by stormwater. Runoff from disturbed soils and impervious areas can contribute to increased sediment loads, heavy metals, petroleum products, deicing salts, warmer water temperatures, various pathogens, and other water quality impairments. Each of these pollutants, particularly in higher concentrations common in the first flush, can degrade water quality for aquatic and non-aquatic organisms that rely on clean water for habitat, irrigation, and drinking. Descriptions of some of the common pollutants and potential non-point source origins can be found in Table 1.



Storm drain cap in concrete channel.



Unfiltered pollutants entering landscape from stormwater outlet.

STORMWATER POLLUTANTS

POLLUTANT TYPE

EXAMPLES AND SOURCES

CONCERNS

SEDIMENT



Sand, Silt, and Clay.

Dirt roads, parking lots, poorly maintained trails, overgrazed pastures, post-fire landscapes, poor ground cover and bare soil in the road right-of-way or medians, etc.

Sediment is the most common stormwater pollutant in semiarid regions with poor ground cover. Sand, silt, and clay textures are easily mobilized in stormwater before settling in rivers, ponds, and wetlands. Excess sediment can pose problems by increasing turbidity which reduces visibility for fish and warms water temperatures by absorbing light. Sediment can also bury infrastructure such as culverts, adhere to and transport heavy metals, and cover cobble and gravel stream beds where benthic macroinvertebrates live or fish lay eggs.

METALS



Zinc, copper, lead, chromium, arsenic, cadmium, etc.

Parking lots/roads where pollutants accumulate between storms, naturally occurring in some soils, industrial areas, etc.

Dozens of different types of heavy metals can be present in stormwater runoff. Copper, zinc, and lead are the most common due to the deterioration of automobiles. Metals are generally positively charged allowing them to bond easily to negatively charged clay sediment particles. If deposited in water, metals can be absorbed by aquatic organisms where they accumulate and are passed up the food chain leading to sickness or death.

PATHOGENS

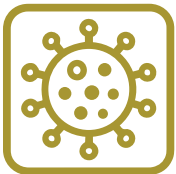

Viruses, bacteria (e.g. E. coli)

Leaky sewer pipes, poorly functioning septic systems, and pet/animal waste throughout a watershed.

Viruses, bacteria, and other pathogens can enter stormwater from livestock, waterfowl, pets, and leaky sewer lines or septic systems. E. coli is one of the most common forms of bacteria in stormwater and is often present with other pathogens that can lead to sickness in people and animals.

ORGANIC CHEMICALS



Pesticides, herbicides, pharmaceuticals, etc.

Runoff from farms, storm drains that discharge directly into the rivers, etc.

There are numerous organic chemical pollutants that have been found in stormwater including herbicides, pesticides, petroleum products, pharmaceuticals, etc. The presence and impacts of many of these pollutants are understudied, but could contribute to toxic conditions in water resources that lead to various health problems in aquatic organisms and people.

Table 1. Common stormwater pollutants and some of their possible origins.

POLLUTANT TYPE

EXAMPLES AND SOURCES

CONCERNS

NUTRIENTS



Nitrogen, phosphorus
 Runoff from farms or grazing areas, overapplication of fertilizers on parks, etc.

Fertilizers composed of nitrogen, phosphorus, and other nutrients can be beneficial to plant growth. However, they can be problematic if applied excessively. The presence of nutrients in rivers, ponds, and other water bodies can promote algae growth which consumes dissolved oxygen during the decomposition process (i.e. eutrophication). Reductions in dissolved oxygen in water can lead to suffocation in fish and other aquatic organisms.

SALTS



Sodium chloride, calcium chloride
 Asphalt streets or parking lots that receive deicing treatments in winter; Bare soils in fields that rapidly evaporate leaving salts/minerals on the surface.

During the winter many municipalities apply de-icing salts to roads, sidewalks, and parking lots which increases total dissolved solids (TDS) in stormwater. The distribution and accumulation of salts near streets or on agricultural fields over time (e.g. via acequia irrigation) might impede the ability of plants to utilize soil moisture.

HEAT



Heat islands
 Bare compacted soil with low moisture content, artificial turf fields, large unshaded parking areas, concrete or asphalt surfaces, etc.

Impervious surfaces and bare soils can retain heat and increase stormwater temperatures during storm events. Warmer water holds less dissolved oxygen which can impact breathing, metabolism, and reproduction in aquatic organisms.

Urban heat islands can also drive plants to deplete soil moisture more rapidly during transpiration, leaving vegetation more vulnerable to permanent wilting point between precipitation events or irrigation periods. UHI also drives energy use needed for cooling, potentially creating a vicious cycle of fossil fuel consumption for energy while increasing greenhouse gas emissions.

Table 1. Common stormwater pollutants and some of their possible origins.

GSI FEATURES

CAPTURING RUNOFF WITH GSI FEATURES

Alternative and complementary methods of mitigating stormwater runoff and pollution to those commonly used in grey infrastructure can be achieved with green stormwater infrastructure (GSI), a collection of strategies and structures that work to mitigate negative impacts to stormwater quality and quantity from the built environment. GSI is subset of Green Infrastructure (GI) strategies, which encompass a broader approach to managing precipitation/water/hydrology in the built environment through constructed or engineered features that utilize natural systems (e.g. soils, plants, mycelium, etc.) to provide ecosystem services. Common GI systems include urban forestry to cool streets, constructed wetlands to filter wastewater, green roofs to reduce energy needed to regulate building temperatures, etc.

GSI structures commonly used in the Southwest include rain gardens, bioretention basins, bioswales, street chicanes, etc. (depicted to the right), and are referred to as GSI "features" for the purposes of this manual. A GSI feature is a complex system made up of modular GSI "components," which are presented in the section of this manual that begins on page 34.

Through intentional design and installation of these features, including appropriate soils, mulches, and plants, GSI can capture, treat, and infiltrate runoff near its source. In addition to reducing stormwater runoff, GSI and the biological communities it supports can remediate stormwater pollutants, offset potable water consumption, conserve soil, shade and cool heat-retaining streets and buildings, enhance wildlife habitat, improve aesthetics around public spaces and commercial districts, help calm traffic, etc.

FEATURE

BIORETENTION BASIN



BIOSWALE



BUMP-OUT OR CHICANE



DEFINITION

A GSI feature aimed at mitigating stormwater runoff and pollution through a series of physical, biological, and chemical treatments. Unlike rain gardens, bioretention basins tend to have deeper engineered soil profile layers (e.g. sand, compost, woodchips, etc.) intended to filter, absorb, and degrade specific pollutants and enhance soil medium for phyto- (plant) and rhyzo- (root zone) remediation. These structures are often used in wetter climates with pollutants that end up in larger water bodies, but they also provide important infiltration and treatment benefits in more arid regions.

A stormwater management feature that can share characteristics with rain gardens and bioretention basins. The name is more indicative of the shape of the structure (i.e. long, broad ditch with gently sloping edges) that can serve to pool (on contour) or convey (on slope) stormwater as it is being treated.

Traffic calming features intended to slow automobiles where pedestrians are present (e.g. on-street parking, school zones, parks, trails, crosswalks, etc.). These street narrowing structures can be enhanced for shade, stormwater treatment, and aesthetics by converting them into GSI such as rain gardens. A bump-out is a singular instance of this feature, whereas a chicane is a plural system of bump-outs designed to systematically weave traffic by inducing an "S" shaped curve in the road.

The intention of this manual is to guide the design and implementation of GSI as a Best Management Practice (BMP) that is regionally specific to Santa Fe County.

MANAGING RUNOFF IN RURAL CONTEXTS

Approximately 96% of the land in Santa Fe County is rural, comprising a total area of 1,833 square miles and accounting for 35% of its total population [source]. Though GI and GSI interventions are typically used in the context of urban environments, the high percentage of rural land in Santa Fe County makes it important to address the management of stormwater runoff and its erosive potential in rural environments as well.

Due to this regional significance, other structures not commonly referenced in GSI applications, but which are similarly beneficial at slowing and infiltrating runoff in rural contexts, have been included in this manual. These rural water management and erosion mitigation structures are presented alongside GSI ("features") as a distinct category of BMPs to be used in rural environments with disturbed soils. Referred to as "upland BMPs" throughout this manual (depicted in the bottom right), common examples of these structures include one-rock dams, and rock rundowns, etc.

FEATURE

PARKING SPACE RETROFIT



RAIN GARDEN



UPLAND BMPs



DEFINITION

An easily replicable type of rain garden that is predicated on the removal of an existing parking space (or the omission of a space in a new lot). The space is transformed into a shallow basin intended to capture and treat runoff from adjacent parking areas. The passively harvested stormwater can serve to irrigate vegetation and trees, whose canopy helps to cool impervious surroundings. A parking space retrofit also works to offset runoff, increase urban forestry, remediate pollutants, and improve the commerce of businesses around the parking lot.

A common GSI feature that captures and retains runoff from impervious areas. The stormwater is stored in shallow basins and can be used as passive irrigation for plants that remove pollutants, increase shade, improve community aesthetics, and address habitat loss.

Upland BMP structures, generally made of stone (without wire, cement, or other bonding agents), serve to enhance soil moisture and armor soil against erosion on uplands or in small channels. Many of these structures have been elaborated on by Bill Zeedyk and others. For this manual, four structures are reviewed as independent components, including media lunas, one-rock dams, rock rundowns, and Zuni bowls. In some situations these individual components could be used in conjunction as part of a larger feature to address a series of erosion problems from upslope to downslope (e.g. see page 43).

FEATURED COMPONENTS:

	INLET	P.70
	SEDIMENT TRAP	P.82
	BASIN BORDER (STONE)	P.74
	WEIR	P.86
	OUTLET	P.90
	SOILS	P.92
	VEGETATION	P.100
	MYCO-SPONGE	P.102

DEFINITION

Bioretention soil profiles are generally intended to rapidly infiltrate stormwater while also filtering pollutants. Design standards have generally been developed for wetter climates where prolonged pooling or a shallow water table could be problematic. For this reason, coarse textured underdrains (e.g. washed gravel with perforated pipes) are often installed beneath other amended soil profiles to reduce standing water and anaerobic soil conditions. Most bioretention basins in Santa Fe County will not need to include an underdrain. Instead, deep layers of sand/compost mixes that cap a woodchip layer might be a good alternative in this semiarid climate. The sand/compost layers should infiltrate stormwater faster than native soil, while the underlying woodchips will offer a highly porous substrate that will store water and nutrients for adjacent plants.

CONSTRUCTION NOTES:

1. Identify any subsurface utilities where a bioretention basin might be installed.
2. Determine the dimensions of the proposed basin taking into account desired pooling depth, amended soil and filtration layer depths, area of contributing runoff, etc.
3. Excavate soil to a depth that allows for replacement with amended soil layers, mulch, and pooling depth.
4. *Optional:* Construct basin edges ensuring that any stone or block is set on a compacted soil bench (i.e. do not build on top of amended soil that might shift or decompose over time).
5. Add layers of amended soil for filtration purposes. Ensure that mulches are not prone to floating out due to stormwater current moving through the basin (note that woodchips should be free of weed seeds and any other chemicals. Over time the woodchips will likely settle and decompose which might increase the pooling depth of the basin.)
6. Build sediment trap.
7. Plant vegetation according to shade, habitat, pollutant remediation goals, pooling and drought tolerance depths.
8. Install inlet and deflector if necessary.

BIORETENTION BASIN

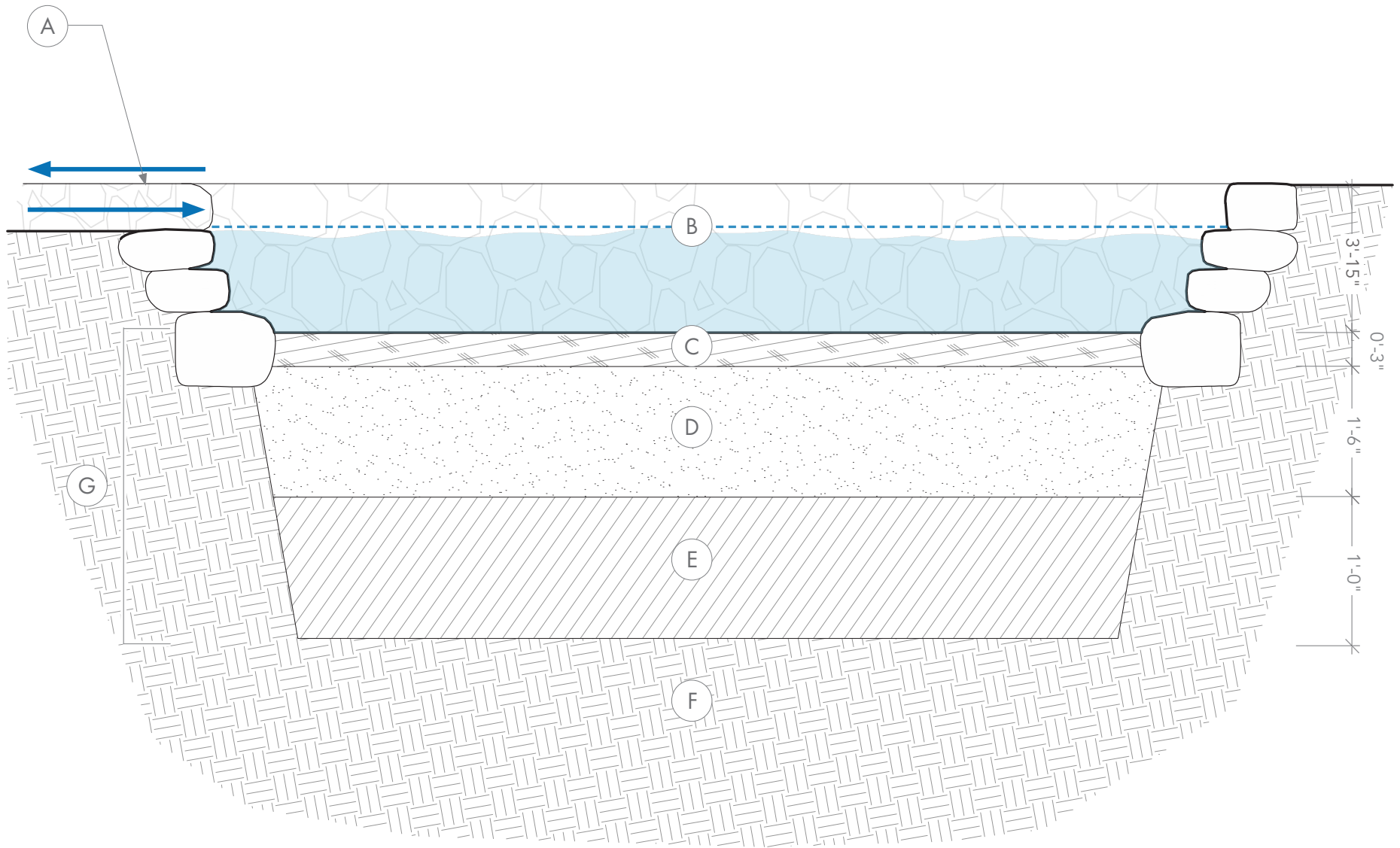

Cross Section of Bioretention Basin

KEYED NOTES:

- A. Inlet (outlet could be same opening as inlet to maximize pooling depth or at an alternative location where discharge is desired. If using a pipe as an outlet, consult a licensed contractor/engineer).
- B. Pooling depth \leq 1.25 feet. Shallower pooling depths should be used where underlaying amended and native soil might not infiltrate stormwater runoff in less than 24 hours.
- C. A 0-3" woodchip layer can be added to reduce ET in basins with reliable pooling (i.e. no erosive stormwater velocity).
- D. Primary filter layer: a highly porous substrate not prone to floating or eroding (e.g. 1:2 mix of compost : sand). This layer might be too wet (during storms) or dry (between storms) to support most plants aside from grasses.
- E. Secondary Filter Layer: An optional, highly porous substrate to provide rapid infiltration and desired filtration. In wet climates this layer typically includes washed concrete sand, however in semiarid climates woodchips that would typically float away in upper layers could be used in this horizon to provide long-term nutrients to adjacent vegetation.
- F. Native Soil.
- G. Recommended depth of filter layer(s) ~ 12-30" total.

MAINTENANCE NOTES:

- 1) Remove impediments to flow at inlet and outlet.
- 2) Monitor and clean sediment trap.
- 3) Irrigate and maintain vegetation as needed.
- 4) Assess and address any other concerns (e.g. erosion, trash, etc).



Bioretention Basin with Stone Edges Prior to Planting

BIOSWALE



FEATURED COMPONENTS:



INLET P.70



SEDIMENT TRAP P.82



ROCK RUNDOWN P.48



OUTLET P.90



SOILS P.92



VEGETATION P.100



MYCO-SPONGE P.102

DEFINITION

A stormwater management feature that can share characteristics with rain gardens and bioretention basins depending on pollutant remediation standards. The name is more indicative of the shape of the structure (i.e. long, broad ditch with gently sloping edges) that can serve to pool (on contour) or convey (on slope) stormwater as it is being treated. The gradually sloping edges of a bioswale sometimes results in a broader and deeper footprint than other GSI features. Appropriate design of weirs and outlet elevations is critical to ensure that pooling depth does not become problematic or dangerous.

CONSTRUCTION NOTES:

1. Identify any subsurface utilities where a bioswale might be installed.
2. Determine the dimensions of the proposed swale taking into account desired pooling depth, amended soil and filtration layer depths, area of contributing runoff, etc.
3. Excavate the swale to a depth and slope that allows for desired pooling or stormwater conveyance.
4. Apply nutrient rich amended soil to improve fertility for vegetation and/or other soil substrates to address pollutants.
5. Build sediment trap.
6. If the swale is deep and berm edges cannot be lowered to create an outlet with a safe pooling depth, then install a pipe overflow with appropriate stormwater depth. An underdrain (i.e perforated pipe surrounded by coarse, washed gravel and a weed barrier) is probably unnecessary in Santa Fe County's climate.
7. Plant vegetation according to shade, habitat, pollutant remediation goals, pooling and drought tolerance depths.
8. Add mulch layer according to slope, erosion, and nutrients (e.g. woodchips in flat/pooling basins; cobble or riprap seeded with grasses where erosion might occur).
9. Install deflector at inlet if necessary.
10. Irrigate, weed, and perform other maintenance as necessary.

BIOSWALE

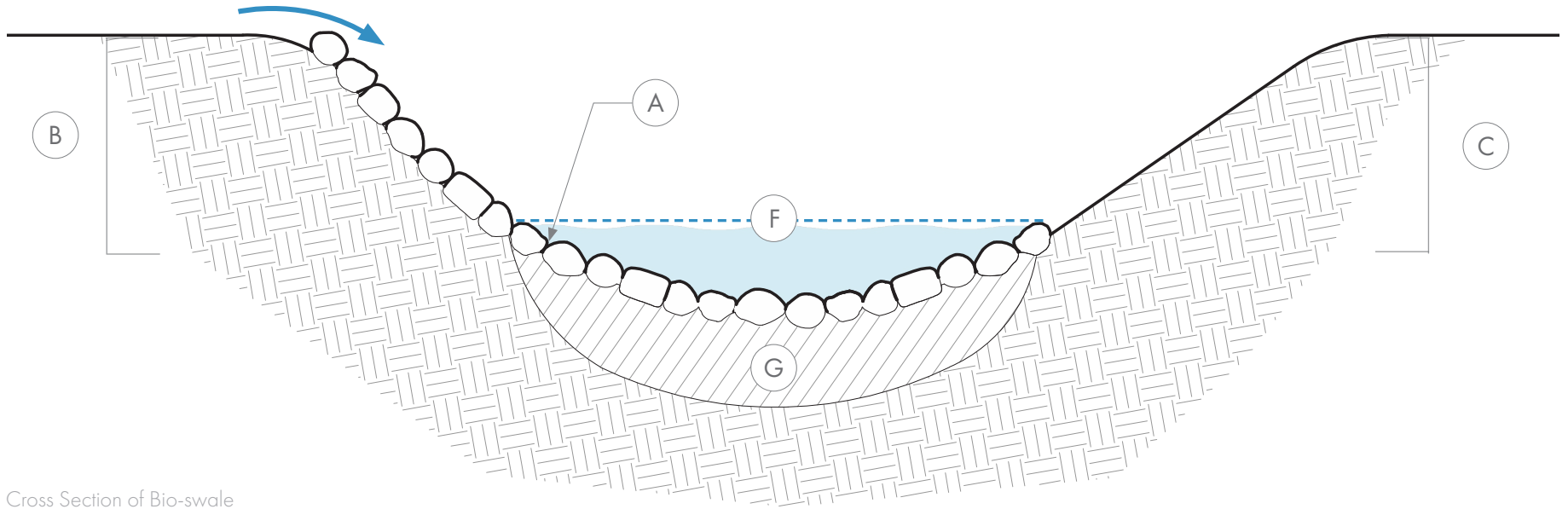

Cross Section of Bio-swale

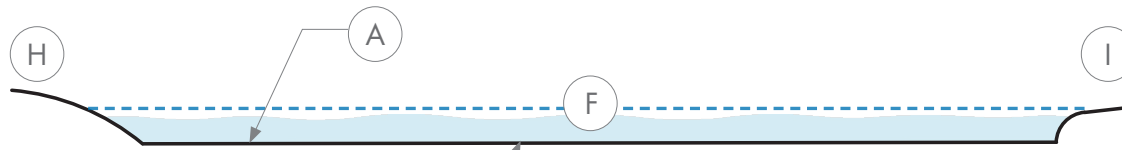

Section Detail of Bio-swale with a level bottom

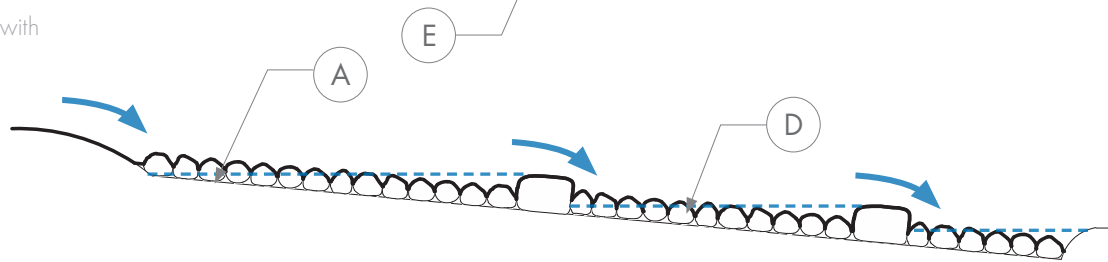

Section Detail of Bio-swale with a sloping bottom

KEYED NOTES:

- A. Maintain gentle slopes (0–3% on bottom of swale; <3:1 slope on berm edges).
- B. Use cobble on berm edges seeded with grasses if slopes are steep or prone to erosion.
- C. Use jute fabric mulch with seed and binder if slopes are not prone to severe erosion.
- D. Use cobble mulch and/or weirs to slow flow and reduce potential erosion on steeper swale bottoms ($\geq 2\%$ slope).
- E. Use woodchip mulch or seed with grass on swale bottoms without a severe grade (0–1% slope).
- F. Pooling Depth 0"–12".
- G. Amended Soil 0"–12".
- H. Inlet.
- I. Outlet. Ensure elevation of outlet sets appropriate pooling depth.



Bioswale with cobble edges (due to steep edge slope) and seeded grass bottom (due to gradual bottom slope).

MAINTENANCE NOTES:

- 1) Remove impediments to flow at inlet and outlet.
- 2) Monitor and clean sediment trap.
- 3) Irrigate and maintain vegetation as needed.
- 4) Assess and address any other concerns (e.g. erosion, trash, etc).







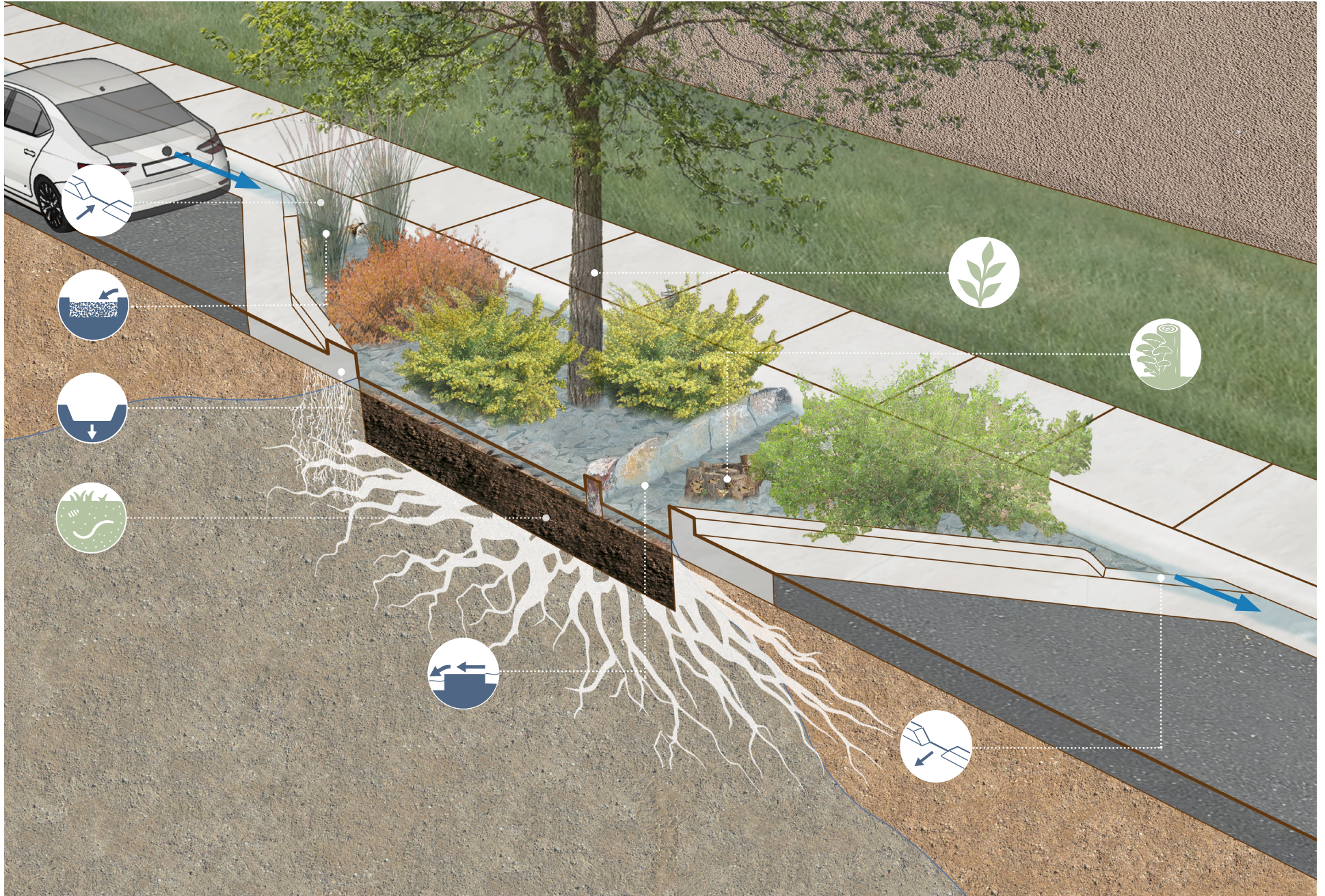

Bioswale with stone-lined channel bottom and edges (due to steep edge and bottom slope).

BUMP-OUT / CHICANE



FEATURED COMPONENTS:

	INLET	P.70
	SEDIMENT TRAP	P.82
	BASIN BORDER	P.74
	WEIR	P.86
	OUTLET	P.90
	SOILS	P.92
	VEGETATION	P.100
	MYCO-SPONGE	P.102

DEFINITION

A bump-out is an extension of a curb that intrudes into a street that can serve to calm traffic at sites with on-street parking, pedestrian crossings, etc. A series of bump-outs on opposite sides of a street used to create an “S-curve” to slow traffic is called a chicane. Bump-outs and chicanes can be adapted with GSI components to manage stormwater and improve urban forestry. There are no standard dimensions for a bump-out, but if used to improve tree cover at a site with street-side parking or low traffic speeds (<30 mph), then consider the following suggestions.

CONSTRUCTION NOTES:

1. Identify any subsurface utilities where a bump-out might be installed.
2. Determine the dimensions of the proposed basin, taking into account the space that can be compromised, volume of runoff and catchment opportunities (see table with volumes), rooting volume needed for potential tree species, slope of street and influence on stormwater inlet/outlet locations, and traffic ordinances governing speed, road width, visibility, pedestrian protections, etc.
3. Remove asphalt (if space is to be retrofitted) and install standard curb/gutter perimeter while leaving an opening for the inlet and outlet.
4. Remove underlaying soil to a depth that allows for replacement with amended soil, cobble mulch, and pooling depth.
5. Amend soil up to 30" in depth (if subsurface utilities and other infrastructure allows) to improve porosity and nutrient content.
6. Build sediment trap.
7. Plant vegetation according to shade, habitat, pollutant remediation goals, and pooling and drought tolerance depths.
8. Install a weed barrier or heavily seed with low growing dense grass (e.g. blue grama, buffalo grass) before mulching with 4" to 8" size cobble/riprap if outlet is installed downslope of inlet (i.e. stormwater will flow through basin potentially causing erosion).
9. Install reflective caution signs facing oncoming traffic and/or pedestrian caution signs if installed near a crosswalk.

MAINTENANCE NOTES:

- 1) Ensure safe visibility for traffic and pedestrians through appropriate planting, pruning, and weeding.
- 2) Irrigate, remove sediment, and conduct other maintenance as needed.

BUMP-OUT / CHICANE

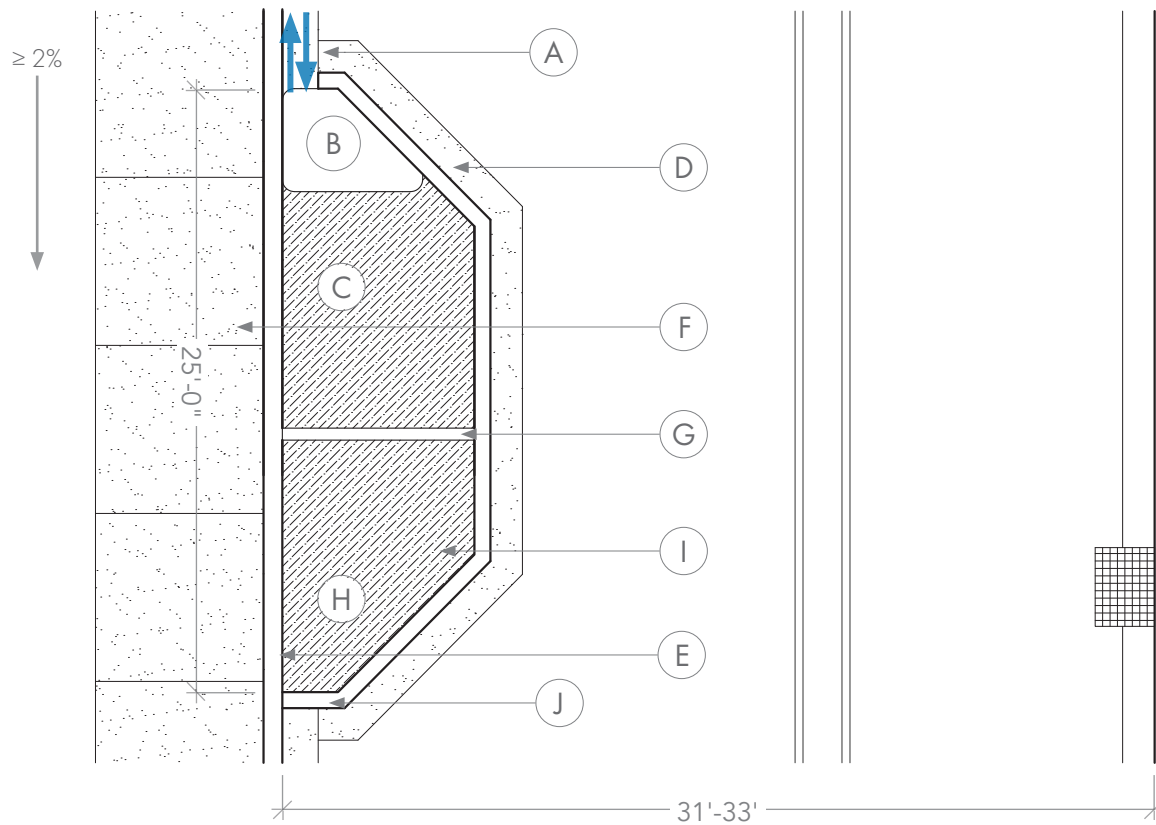
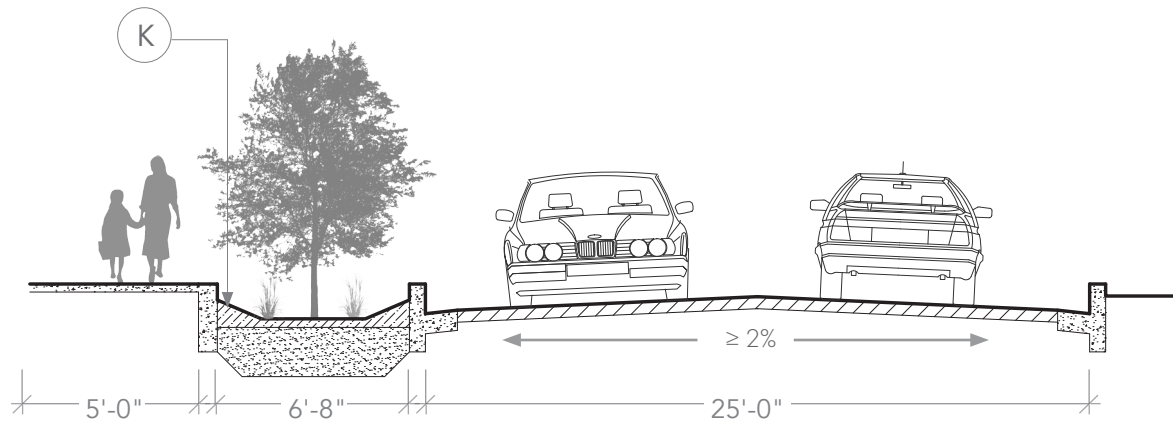

KEYED NOTES:

- A. If inlet gutter is lower than all curb elevations, then the inlet can serve as an outlet.
- B. Sediment trap.
- C. <30 degree angle for approaching traffic.
- D. Standard curb/gutter.
- E. A wider curb can be used to alert pedestrians of uneven surface in basin below.
- F. Bump-out can intrude into sidewalk where right-of-way space permits.
- G. Weirs to pool stormwater in basins with extended length or steeper slopes.
- H. ≥ 4" cobble or riprap, if outlet installed downslope.
- I. Curb/gutter can be constructed at 90 degree angle on downslope end of basin that is not approached by traffic.
- J. If inlet gutter elevation is higher than curb, then install outlet.
- K. Amended soil with tapered cobble surface to reduce erosion.



Left, Right: Bump-out rain gardens in urban streetscape.

IMPERVIOUS AREA (sqft)	ESTIMATED RUNOFF FROM 0.3" STORM (gallons)	GSI AREA NEEDED TO CATCH 0.3" STORM ASSUMING 6" OF PONDING DEPTH (sqft)	ESTIMATED RUNOFF FROM 0.5" STORM (gallons)	GSI AREA NEEDED TO CATCH 0.5" STORM ASSUMING 6" OF PONDING DEPTH (sqft)
500	75	20	125	33
1000	150	40	249	67
2000	299	80	499	133
3000	449	120	748	200
4000	598	160	997	267
5000	748	200	1247	333

Ideally, bump-out volumes should harvest ≥ 0.3-inch storm events from the impervious area that flows to the inlet. This will require closer spacing of small GSI features or the implementation of larger basins when opportunities exist.

PARKING SPACE RETROFIT



FEATURED COMPONENTS:

	INLET	P.70
	DEFLECTOR	P.64
	SEDIMENT TRAP	P.82
	BASIN BORDER.....	P.74
	OUTLET.....	P.90
	SOILS	P.92
	VEGETATION	P.100

DEFINITION

An easily replicable type of rain garden introduced to parking lots with the primary intention of using captured stormwater as passive irrigation to support trees and vegetation for improved shade cover.

CONSTRUCTION NOTES:

1. Identify any subsurface utilities and slopes where a retrofitted parking space rain garden might be installed to ensure its use is suitable for capturing stormwater.
2. Determine the dimensions of the proposed basin. Length is generally 16'-18', but width can vary depending on the number of spaces that can be compromised, rooting volume needed for potential tree species, and slope that will make up the width of the rain garden (e.g. if the slope > 3%, then the width of the basin should be extended to >8.5', or else pooling could be minimal/uneven, becoming concentrated on the downslope side).
3. Remove asphalt (if retrofitting an existing parking space) and install standard curb/gutter perimeter while leaving an opening for the inlet/outlet.
4. Remove underlying soil to a depth that allows for replacement with amended soil, cobble mulch, and pooling depth.
5. Amend soil with 3" of compost and integrate up to 30" in depth (if possible) to improve porosity and nutrient content.
6. Build sediment trap.
7. Plant vegetation according to shade, habitat, pollutant remediation goals, and pooling and drought tolerance depths.
8. Install a weed barrier or heavily seed with low growing dense grass (e.g. blue grama, buffalo grass) before mulching with ~4" sized cobble or riprap to reduce weed growth.
9. Install deflector if necessary.
10. Irrigate, weed, and perform other maintenance as necessary.

WIDTH	LENGTH	AVERAGE POOLING DEPTH (inches)	POOLING VOLUME (gallons)	NOTES	AREA OF RUNOFF (sqft)
8.5	16	3	254	Minimum parking space dimensions	2,000-3,500
8.5	18	4	381	Standard parking space dimensions	2,000-3,500
12	18	4	539	Optimum if built new; Allows for good volume and one large tree species	2,000-4,000
17	18	6	1144	Two standard Spaces allows for deeper pooling and one large or two small/moderate tree species	2,500-5,000

A typical parking space is 8.5ft wide X 18ft long. The narrowness of a typical space retrofitted as a rain garden might have limitations in pooling depth. This is because cobble mulch should taper upwards near interior edges to support pedestrians exiting vehicles in adjacent parking spaces. If more area can be compromised to increase width, then deeper pooling volumes can be achieved near the center of the basins. Increased width also expands rooting volume for larger tree species that can cast broader shade.

KEYED NOTES:

- A. Standard curb/gutter (existing).
- B. Deflector.
- C. Inlet.
- D. Sediment trap (with bunch grasses to filter debris).
- E. Cobble mulch laid in a concave shape to centralize pooling.
- F. Open water volume.
- G. Basin borders (new curb/gutter).
- H. Length of slope <3% (<2% is best).
- I. Width of slope <4% (<2% is best; increase width of basin if slope is >3%).
- J. Compost amended soil and mulch. Soils should infiltrate post-storm standing water in <24 hours.
- K. Appropriate plants (see page 112 for selection).
- L. Outlet.

MAINTENANCE NOTES:

- 1) Remove impediments to flow at inlet and outlet.
- 2) Monitor and clean sediment trap.
- 3) Irrigate and maintain vegetation as needed.

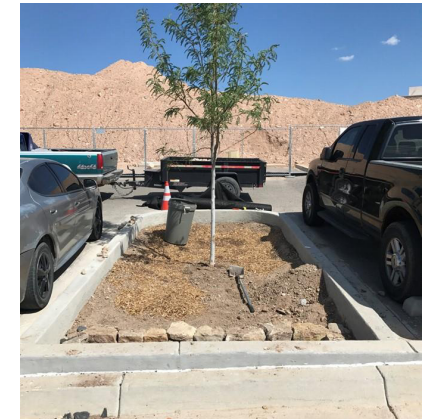

From left to right: Parking space retrofit rain garden at varying stages of construction.

RAIN GARDEN

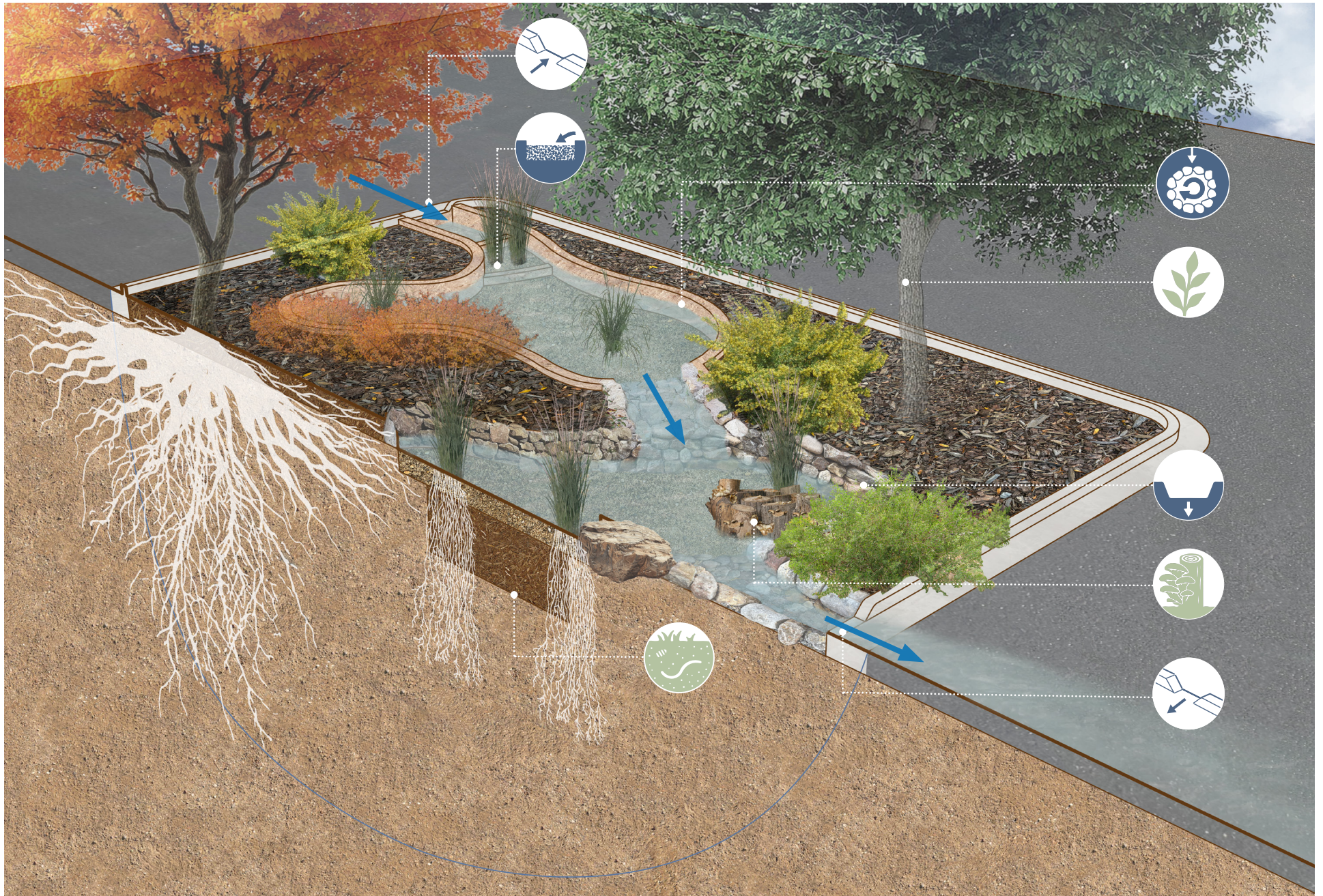

FEATURED COMPONENTS:

	INLET	P.70
	SEDIMENT TRAP	P.82
	BASIN BORDER (STONE).....	P.74
	URBAN ZUNI BOWL	P.81
	WEIR	P.86
	OUTLET	P.90
	SOILS	P.92
	VEGETATION	P.100
	MYCO-SPONGE	P.102

DEFINITION

A common GSI feature that captures and retains runoff from impervious areas. The stormwater is stored in shallow basins and can be used as passive irrigation for plants that remove pollutants, increase shade, improve community aesthetics, and address habitat loss.

CONSTRUCTION NOTES:

1. Identify any subsurface utilities where the rain garden is to be installed.
2. Determine the dimensions of the basin volume of runoff, catchment opportunities, potential plant species, etc.
3. Excavate soil to desired depth taking into account soil amendments, mulch layers, and pooling depth.
4. Construct basin borders, sediment trap, weirs, or other edges/terraces.
5. Amend soils, plant vegetation, and install mulch.
6. Cut deflector and curb inlet/outlet to allow stormwater to enter and exit.
7. Irrigate, weed, and perform other maintenance as necessary.

RAIN GARDEN

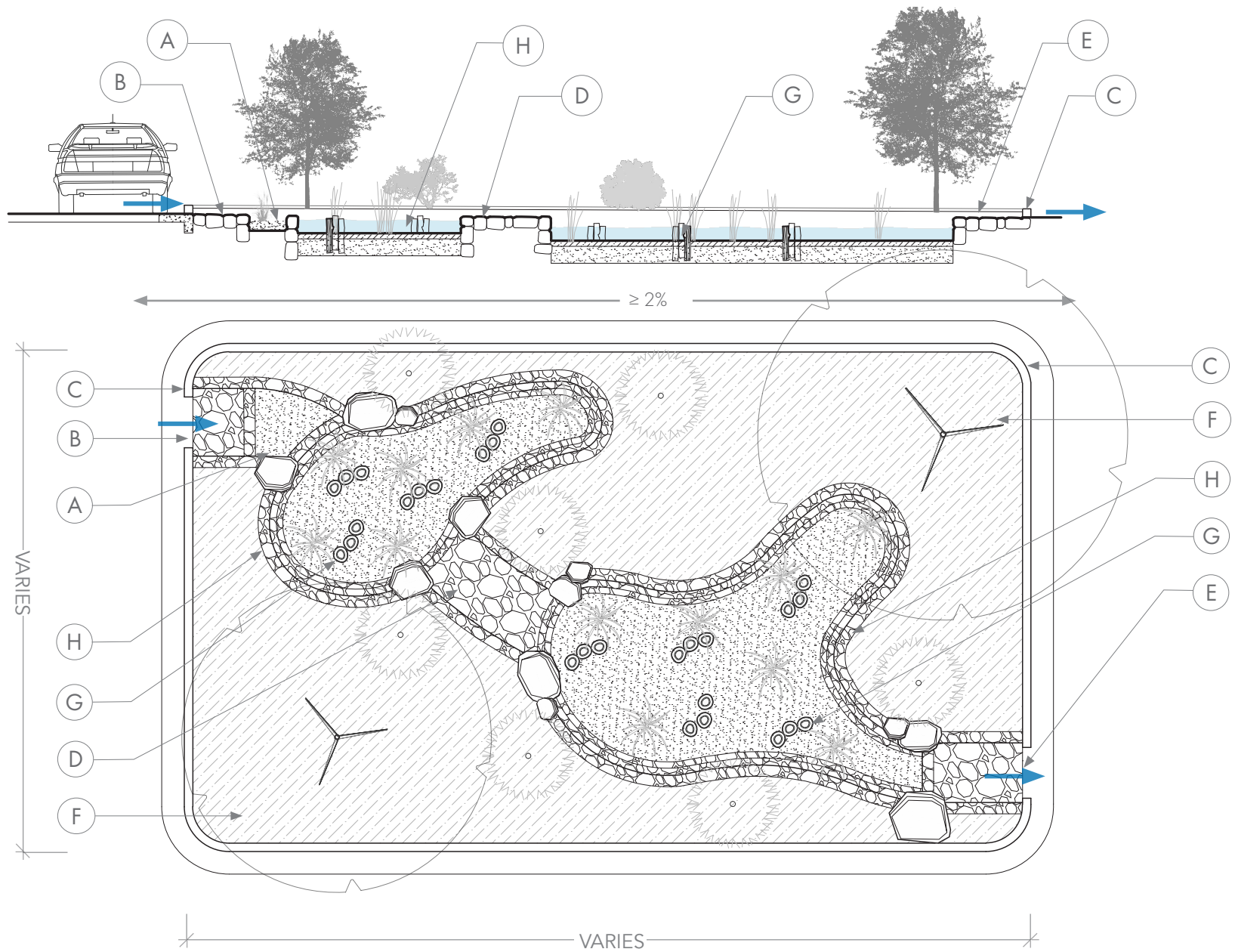

KEYED NOTES:

- A. Sediment trap.
- B. Inlet.
- C. Standard curb/gutter.
- D. Weir.
- E. Outlet.
- F. Planting area with ammended soil.
- G. Mycosponge.
- H. Zuni bowl.

MAINTENANCE NOTES:

- 1) Remove impediments to flow at inlet and outlet.
- 2) Monitor and clean sediment trap.
- 3) Irrigate and maintain vegetation as needed.

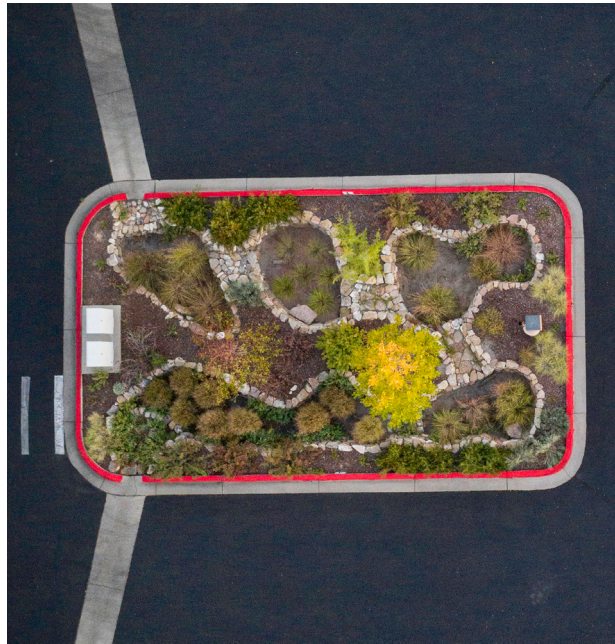

From left to right: a birds eye view (photo credit: Esha Chiochio) and a side view of a rain garden that filters and cleans stormwater pollutants in a commercial parking lot.



From left to right: rain garden along an urban streetscape, rain garden at the end of a street recieves stormwater pollutants before they enter the landscape.

GSI DEEP DIVE



HUMAN HEALTH

GSI promotes and nurtures the human-nature connection in the built urban environment. A widely cited definition of green infrastructure states that it is “an interconnected network of greenspace that conserves natural ecosystem values and functions, and provides associated benefits to human populations” (1,2). The biophilia hypothesis states that there is an innate biological and genetic connection between humans and nature (1). It’s also been said that “nature provides benefits to humans who experience it” (2).

GSI promotes a connection between anthropogenic environments and nature, whereas grey infrastructure often lacks such a connection (1). Biophilia, coined by E.O. Wilson in the early 1980’s, postulates that humans have an affinity for other living things, and this affinity is rooted in our biology (2). Although simply a hypothesis to date, our current urban paradigm lacks the ability to construct human-developed environments that fulfill our biological needs to affiliate with life. Not only does GSI promote regenerative designs—where all anthropogenic inputs to our civilization build upon one another to promote resiliency in the ecosystem—it also promotes a biophilic design. Simply stated, GSI deliberately integrates the inherent human affinity for natural systems within the built environment.

Despite ecological models of human health emphasizing the natural environment as a fundamental contributor to supporting human health and well-being, the natural environment receives relatively little attention in health research



Zeb exploring a GSI feature for fun!

(3). Although the mechanisms underlying the health effects of green spaces are yet to be fully established or understood, some of the suggested by-products include stress reduction, cognition restoration, mitigation of the exposure to air pollution, noise, and heat; an enhancement of social cohesion and community interactions; and an increase of physical activity. (3,4). Exposure to green spaces has been associated with, among others, improved perceived general health, better pregnancy outcomes (e.g., birth weight), enhanced brain development in children, better cognitive function in adults, improved mental health, lower risk of a number of chronic diseases (e.g., diabetes and cardiovascular conditions), and reduced premature mortality (3,4,5).

In one study, Hewitt et al. (2020) provided an introduction of green infrastructure as a win-win solution to urban air pollution, reducing ground-level concentrations without imposing restrictions on traffic and other polluting activities. Air pollution is an important risk factor for health. Urban trees alone in the US remove 711,000 metric tons (1,567,486,684 pounds) of pollutants annually (3). Additionally, trees have the capacity to capture both gaseous and particulate airborne pollutants (6,7). Gases are removed from the air via uptake by leaf stomata (pores on leaves), absorption through leaf surfaces, and particulate matter removal occurs via adsorption (or adherence) to plant surfaces (3,6). Mitigation of air pollution was shown to be effective on the basis that pollutants deposit more efficiently onto vegetation than onto smoother, impervious, artificial surfaces (6).

GSI has also been correlated to studies that show a reduction in crime and violence (8,9). For example, Burley (2018) studied to what extent Portland's green infrastructure initiative reduced neighborhood violence by increasing the availability of new trees to residents of underserved communities as a modality for green infrastructure intervention. They determined a strong negative correlation between the number of trees planted and violent crimes in the years following the planting of trees. Interestingly, this decrease in violence was more pronounced in neighborhoods with lower median household incomes (8,9).



Ria experiencing clean water in a GSI feature!



Leila enjoying a rain garden come to life!

These findings suggest that the inclusion of new street trees in underserved neighborhoods may be one part of the solution to the endemic of violence in such neighborhoods.

GSI further promotes the growth of urban trees, creating microclimates and cooler temperatures. The ability of trees to reduce temperature as well as improve human thermal comfort is consistent across peer reviewed literature (7). Tree canopies provide shade which reduces direct solar radiation. Through evapotranspiration, trees release vapor to the atmosphere and therefore increase relative humidity, decreasing temperature and eventually improving the thermal comfort condition (7). In one study, heat-related diagnoses for heat-sensitive citizens (age 75+) in Oslo were correlated with monthly air temperatures, and green infrastructure tree canopy cover reduced extreme land surface temperatures, thus reducing the overall health risks from heat exposure (5).

Contemporary ecological models of health prominently feature the natural environment as a fundamental component of ecosystem services, ecosystem services being the primary benefits that humans obtain from ecosystems. GSI should be considered an ecosystem service that provides for, sustains, and enhances human health and well-being.

GSI DESIGN COMPONENTS

GSI DESIGN COMPONENTS

In this manual, the term GSI design "component" is used to refer to a category of fundamental design elements that, when combined, make up the larger and more complex system of a GSI "feature." Components are modular in nature and are often paired together in different combinations to enhance the performance of a given GSI feature. Some components needed for GSI design are applied uniformly in all situations (e.g. calculating area of runoff), while others might require specific consideration (e.g. choosing soil textures and mulches to address unique stormwater pollutants).

For the purposes of assessment and design of GSI at different locations within Santa Fe County, some of the most common components to be considered for use in semiarid climates, from upslope to downslope, are defined and described in Figure 3 and Table 2. Information and images depicting when and how to use them, how they are constructed and maintained, and/or common implementation mistakes to avoid when installing them can be found on each component page. A symbol has also been assigned to each component, which can be found in the upper right corner of its corresponding page(s) and is used throughout the diagrams in the features section to help clarify its role within the context of a larger system. Each symbol is color coordinated to reflect which of the following categories it belongs to.

The components are organized into three color-coded categories to help identify the appropriate context for their use, based on the surface conditions of their contributing runoff area. These categories include runoff from disturbed soils (dark green), runoff from

rooftops (tan), and runoff from impervious surfaces (dark blue). Components of an organic nature that can be used in any of the 3 categories, such as soils, vegetation, and mycelium, have been assigned a light green color to avoid confusion. For additional guidance in determining which components are appropriate for use at a given site, consult Figure 3.

Although only the components included in the runoff from impervious surfaces category are considered traditional GSI, all the components presented in this manual are considered BMPs for managing stormwater in their respective contexts and have been included to address the unique range of surface conditions that can be found in Santa Fe County.



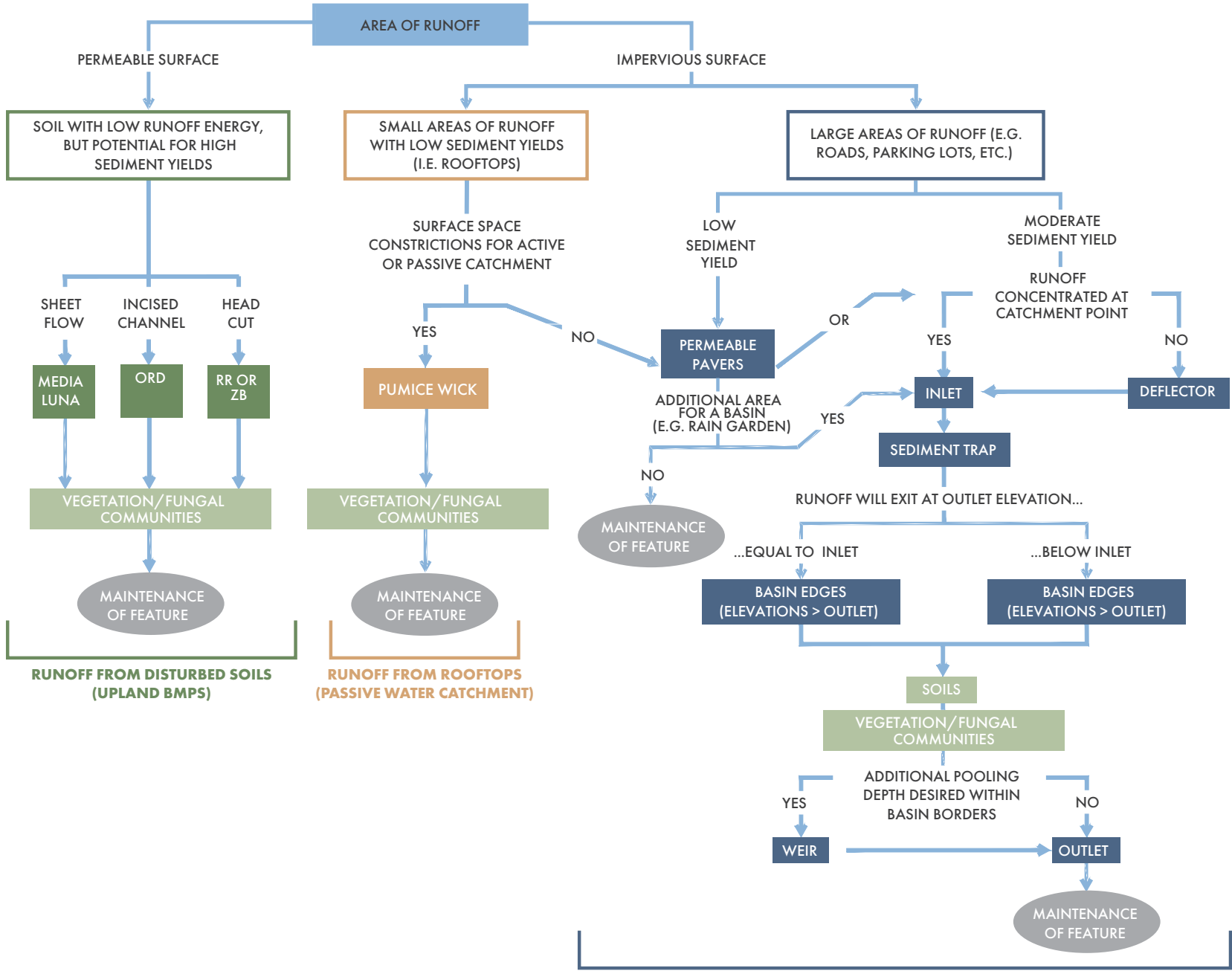

Figure 3. A compilation of components, ordered from upslope to downslope, that can help with GSI and other stormwater management design, installation, and decision making.

GSI DESIGN COMPONENTS

FACTOR INFLUENCING STORMWATER CATCHMENT AND TREATMENT

COMPONENT (UPSLOPE TO DOWNSLOPE)

DEFINITION

Stormwater Origin



Area of Runoff

Pg. 38

The extent and surface conditions of a miniature (e.g. rooftop), moderate (e.g. parking lot), or large (e.g. arroyo/stream) watershed that contributes runoff to a point where stormwater can be treated and harvested in active (e.g. tanks/cisterns) or passive (e.g. soils/permeable basins) catchment systems including Green Stormwater Infrastructure features.

Erosion from Disturbed Soils and Small Channels



Media Luna

Pg. 44-45

A passive water harvesting mulch structure intended to manage sheetflow and small headcuts.



One Rock Dam

Pg. 46-47

A grade control structure—only one rock high—intended to stabilize the bed of a channel by slowing flow, capturing sediment, and recruiting vegetation through passive water harvesting.



Rock Rundown

Pg. 48-49

A structure intended to eliminate a headcut by converting the vertical edge to a manageable grade ($\leq 3:1$ slope) that can be subsequently armored with a stone mulch to reduce erosion and improve soil moisture for vegetation.



Zuni Bowl

Pg. 50-51

A structure intended to remediate a headcut by dissipating flow energy through armored falls and pools.

Stormwater Runoff from Rooftops



Pumice Wick

Pg. 54-55

A highly porous substrate (e.g. cobble wrapped in geotextile fabric) that is used to rapidly infiltrate sediment-free stormwater (e.g. from a rooftop downspout and subsurface perforated pipe) into soils.

Stormwater from Impervious Ground Surfaces

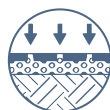

Permeable Pavements

Pg. 60-63

A porous alternative to concrete, asphalt, and other impermeable surfaces that is intended to facilitate increased stormwater infiltration on sidewalks, roads, and parking lots.

FACTOR INFLUENCING STORMWATER CATCHMENT AND TREATMENT

Stormwater from Impervious Ground Surfaces (Continued)

COMPONENT (UPSLOPE TO DOWNSLOPE)

DEFINITION

	Deflector, Drain cap	Pg. 64-69	An obstacle/impediment (raised or depressed) to runoff/drainage that can be used to redirect flow toward an inlet or some other point where stormwater can be more easily harvested and treated.
	Inlet	Pg. 70-73	A point of entry for runoff into a GSI feature intended to slow, infiltrate, and/or treat stormwater.
	Sediment trap	Pg. 82-85	An initial basin used to filter the first flush of stormwater pollutants (e.g. soil, trash, leaf litter, etc.) entering a GSI feature by slowing, pooling, and dropping sediment out before flow progresses to other parts of the basin.
	Basin borders	Pg. 74-79	Boundaries that guide, concentrate, and disperse and pool stormwater throughout a GSI feature. The dimensions (area and depth below outlet) within the basin edges will generally define the pooling volume of stormwater catchment.
	Urban Zuni bowl modification	Pg. 80-81	A rock-lined structure intended to aesthetically lift, pool, and dissipate stormwater energy as it flows through a GSI feature.
	Weirs and Outlet	Pg. 86-91	A point where stormwater can be lifted for increased pooling prior to exiting into an adjacent basin in sequence or exit from the GSI feature altogether.
	Soils	Pg. 92-97	A combination of four ingredients (organic matter, parent material/rock, air, and water) that are naturally ordered into horizons over time at undisturbed sites, but can require amending to improve nutrients, infiltration, and other factors at disturbed locations.
	Vegetation, bacteria, and fungal communities	Pg. 100-105	Biological organisms that can aid in improving habitat, remediating stormwater pollutants, enhancing community aesthetics, etc.

Table 2. Common GSI components needed for proper design aimed at slowing, infiltrating, and treating stormwater runoff.

AREA OF RUNOFF

AREA OF RUNOFF

Every GSI feature is surrounded by a geographic context that has unique conditions and qualities which influence its design and the components that help it function. Before beginning the design process, it is important to perform a thorough and proper site assessment in order to better understand this context—observing and documenting pedestrian traffic, sun exposure, climate patterns, soil health and composition, topography, slope/grade, and, crucially, the area of contributing runoff.

Assessing the area that contributes runoff to a proposed location for GSI or other BMPs is imperative in order to gain an understanding of its capacity, mitigate flood events, identify pollution sources, route overflow drainage, determine catchment points, and identify natural drainage paths to strategically

choose the site of intervention to reduce costs and design constraints. The extent of area and surface conditions (e.g. healthy porous soils, overgrazed pastures, impervious asphalt parking lots, shallow lithic channels, etc.) will influence infiltration rates, and in turn, the volumes and discharge rates of runoff. Determining runoff characteristics for a site will affect the size and type of material needed to slow stormwater and mitigate erosion, the amount of passive irrigation available for vegetation, inlet and outlet parameters of a structure, etc.

Factors or disturbances that increase rates of runoff and can result in erosion include:

- Increased slopes: Stormwater velocity increases down slopes before infiltration can occur.

- Reduced permeability: Infiltration is limited due to soil compaction, sealing (e.g. asphalt/concrete), fine textures (e.g. clay), etc.
- Denuded vegetation: Reduced plant cover, including leaf litter as a mulch, allows raindrop impact to degrade soil structure that typically enhances infiltration rates.

Sites with minimal disturbance might only show evidence of sheet erosion. Increased soil disturbance, however, could lead to the formation of headcuts, rill erosion (i.e. small channels), and ultimately arroyos or gullies (Figure 4).

SURFACE CONDITIONS

In rural situations the area of contributing runoff might be unclear without good contour maps or GIS software such as StreamStats from the USGS (2).



Sheet flow



Headcut



Rill



Gully

Figure 4. Left to right: Sheet flow, headcut, rill, and gullies are varying degrees of erosion processes driven by disturbed soil and stormwater runoff.



Even with these tools or resources, understanding erosion features such as headcuts, rills, and bankfull flow in a channel cross-section might be more important to runoff and erosion mitigation design than knowing the exact watershed area. Design guides such as “Let the Water do the Work: Induced Meandering, an Evolving Method for Restoring Incised Channels” cover many of these factors in greater detail (3). “Incised Channels” cover many of these factors in greater detail (3).

In urban areas or sites with a higher density of impervious surfaces (e.g. rooftops and roads), calculating volumes of runoff requires an understanding of runoff coefficients, a measurement of area that contributes to runoff, and depth of precipitation (by event and annually).

Runoff coefficients are an estimated percentage of precipitation that falls on a surface that will flow to a catchment location (e.g. point in a channel, gutter or storm drain, etc.). For example, undeveloped soils with native grass cover, flat agricultural fields, healthy pasture, or other porous soils will have lower runoff coefficients.

Moderately degraded (e.g. cracks or potholes) asphalt parking lots or disturbed soil with greater slope will shed higher percentages of precipitation to arroyos or storm drains. A pitched metal roof should reliably shed almost all precipitation to a gutter and downspout meaning that estimates of potential catchment are practically equal to precipitation depths. Table 3 presents general runoff coefficients based on surface types.

Measurements of runoff area can be estimated using open-source GIS programs such as Google Earth although ground-truthing minor elevations during snowmelt or low-intensity storm events might be necessary at sites that are relatively flat or with poor grading (Figure 5). In urban situations, many designers will advocate for installation of GSI from a quarter-acre (~10,000ft²) or less impervious surface.

Sites that drain larger impervious areas might require consideration of stormwater discharge (i.e. water volume arriving at a point in time often measured as ft³/sec) instead of just volume (e.g. gallons) due to storm drains or other infrastructure becoming overwhelmed during high intensity storm events. To learn more about estimating discharge rates, consider reviewing topics such as the Rational Method.

SURFACE CONDITIONS	RUNOFF COEFFICIENT
Porous soil (>85% sand) with moderate slope (2-7%)	0.10-0.15
Less porous soil (>40% clay) with moderate slope (2-7%)	0.18-0.22
Permeable Pavers*	0.10-0.90
Gravel road	0.30-0.70
Brick	0.70-0.85
Asphalt	0.70-0.95
Roofs (flat gravel – pitched metal)	0.75-0.95
Concrete	0.80-0.95

Table 3. Runoff coefficients vary for different soil textures, slopes, and other surface conditions. *Note that runoff coefficients for permeable pavers can be highly variable depending on pore space at the surface, depth and type of porous substrate, maintenance, and sediment sources.



Figure 5. The rain garden on the left maximizes stormwater catchment because asphalt grades were installed properly. The rain garden on the right misses almost 2,000sqft of runoff (i.e. thousands of gallons annually) because asphalt grades were off by an inch!

AREA OF RUNOFF

ESTIMATING PRECIPITATION DEPTH

A measurement of precipitation depth is the final factor needed to estimate stormwater volumes from different surface conditions. Precipitation measurements in a region can vary by season, storm type, and topographic features. For example, a frontal storm might result in a broad and more evenly distributed precipitation depth across an area while a high intensity convective thunderstorm could drop a lot of rain in an isolated location.

Weather Underground provides real-time weather data including precipitation information uploaded from residential climate enthusiasts (4). If proper installation of the weather stations can be verified (e.g. absence of overhead obstructions near a precipitation gauge), then reasonable short-term data for a specific area can be viewed. A better long-term weather data source is usually available through NOAA with many gauges typically sited near local airports (5).

Combining runoff coefficients, areas of runoff, and precipitation depth is the first step to determining runoff and GSI design; particularly in urban situations or from rooftops. An example of how to calculate runoff can be found to the right.

GREEN STORMWATER INFRASTRUCTURE RUNOFF AND CATCHMENT PRACTICE EXAMPLE

Estimating runoff volumes for GSI design typically assumes stormwater originating from an impervious surface (e.g. rooftop, asphalt road or parking lot, concrete sidewalk, etc.) rather than a more permeable surface (e.g. bare soil, pasture, etc.). To estimate volumes, it is important to know the extent of impervious area in square feet, the depth of a storm in inches, and a runoff coefficient based on the surface type as a percentage. A cubic foot of water is equivalent to 7.48 gallons or 7.48g/ft³. This means that a 1-inch storm falling on a square foot of ground would be 0.623 gallons/inch-ft² or 1 ft/12-inches X 7.48 gallons/ft³. Therefore a 0.25-inch storm falling on a 2,500ft² asphalt parking lot would generate 312 gallons of runoff.

$$\frac{0.25\text{in}}{\text{inch}} \times \frac{0.623\text{gallons}}{\text{inch ft}^2} \times \frac{2500\text{ft}^2}{\text{ft}^2} \times \frac{0.8 \text{ (or 80\%)}}{1} = 312 \text{ gallons}$$

If the same storm depth fell on a pitched metal roof with equal dimensions, the volume of runoff would increase to 370 gallons due to the higher runoff coefficient.

$$\frac{0.25\text{in}}{\text{inch}} \times \frac{0.623\text{gallons}}{\text{inch ft}^2} \times \frac{2500\text{ft}^2}{\text{ft}^2} \times \frac{0.95 \text{ (or 95\%)}}{1} = 370 \text{ gallons}$$

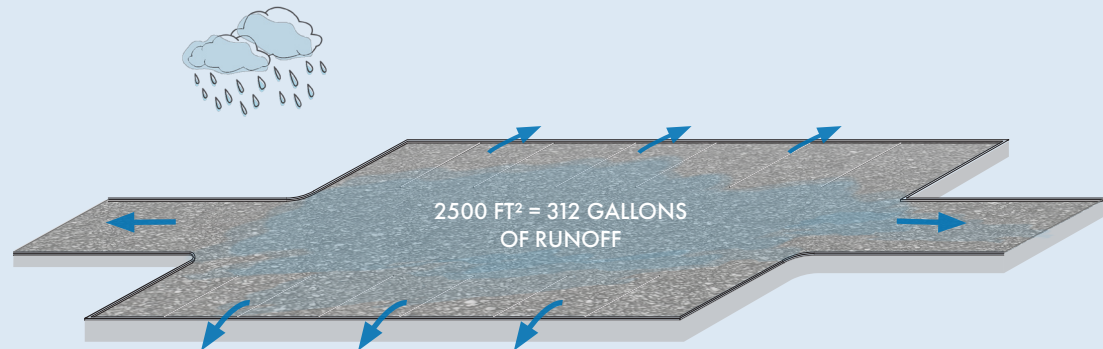



URBAN HYDROLOGY

Impervious surfaces in urban environments have long been recognized as a critical factor that influences rainfall-runoff relationships (1,8). When once-undisturbed land masses undergo anthropogenic modifications in which they are converted into impervious surfaces—such as parking lots, buildings, and roads—it significantly changes ecosystem hydrology by reducing infiltration rates and surface water retention storage capacity, while simultaneously increasing runoff rates (2). Conventional stormwater management practices are designed to dispose of runoff water from impermeable surfaces immediately, leading to decreases in infiltration and increases in surface runoff, without treatment of pollutants (3,8).

Interestingly, studies of stormwater have been most comprehensive in cities where this source of pollution drains directly to ocean ports and other estuaries. Very limited studies have been performed in desert ecosystems where water is a more limited resource (4). Desert ecosystems are unique in their ecology, especially with concern to precipitation (10). Desert soils in general have a very limited stormwater infiltration capacity due to low levels of organic matter and limited biological soil cover (10). Compounding this issue further is the topography of these ecosystems, where sloped land surfaces create sheet flow that increases erosion during major storm events (10).

In semiarid climates, a significant component of recharge to aquifers occurs along the mountain front. “Mountain-front-recharge” (MFR) is a

hydrology term used to describe the contribution of mountain regions to the recharge of aquifers in adjacent basins (6). Basin recharge through direct infiltration of precipitation is limited due to low annual precipitation volumes, deep vadose zones, and water scavenging vegetation that is typically found in dry climates (6).

The primary impact of the urbanization of freshwater stream systems is the process of effective imperviousness (EI), the proportion of a catchment area covered by impermeable surfaces (7). There are two types of EI in urban environments, directly connected impervious areas (DCIA), and unconnected impervious areas (UIA)(1). DCIA comprises all impervious surfaces in direct connection to the overall drainage system and downstream freshwater ecosystem. In urban environments, it is important to note that although buildings and housing developments are considered impervious structures, the surrounding land area can be classified as pervious. In this way, runoff from UIA has the potential to spread and infiltrate before it reaches the drainage system.

In small storm events in the neighboring Bernalillo County, modeling simulations found that all runoff originates from DCIA and that UIA contributed no flow (1). Microscale hydrologic modifications in larger urban environments have shown to be extremely efficient in the capture of stormwater and overall water conservation at the source of precipitation. In one study using residential parcels in Los Angeles, California, data showed that with the use of small-scale

water harvesting techniques, including gutters from roofs and driveways to detention basins, 97% of runoff was eliminated from the street (9). Stormwater detention under our current management practice utilizes very large detention basins (macroscale hydrologic modifications), often devoid of vegetation. The Santa Fe County GSI manual is designed to address runoff issues in both rural and urban environments by utilizing microscale hydrologic modifications, which are shown in the referenced literature, to increase stormwater infiltration and aquifer recharge.

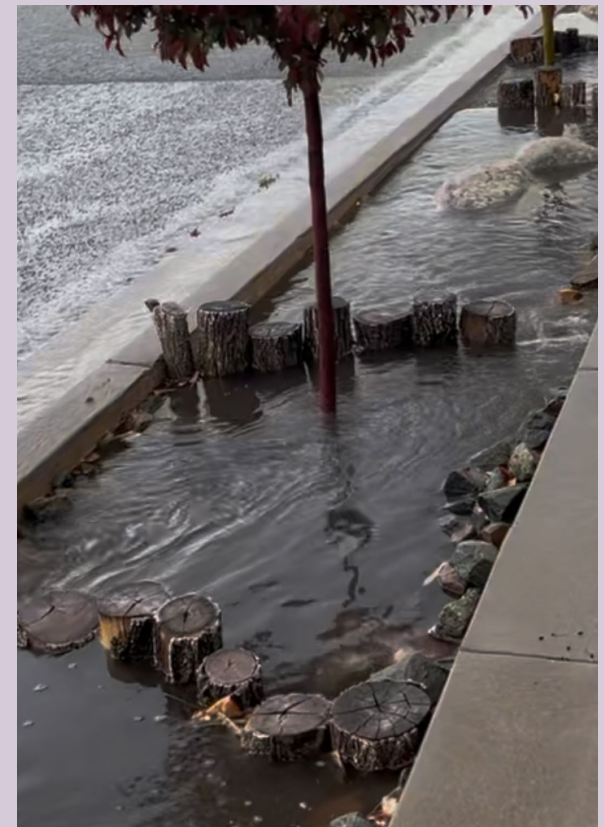

Rehydrating the urban environment using GSI rain garden.

RUNOFF FROM DISTURBED SOILS

RUNOFF FROM DISTURBED SOILS

While not traditionally considered to be GSI, components including media lunas, one rock dams, rock rundowns, and Zuni bowls (Figure 6) can help mitigate low energy stormwater runoff and erosion on upland sites. Because much of Santa Fe County is rural, this section has been included in the manual to help property owners conserve soil resources associated with local agricultural and livestock economies.

Media lunas can be used at locations to enhance sheet flow at depositional zones (e.g. where stormwater emerges onto flatter terrain from a channel) or collection points (e.g. where sheet flow is being lost above a headcut or channel). If sheet flow is lost to a headcut, the disturbed pour-over point can be remedied by tapering the vertical edge into a more manageable slope (e.g. 3:1) with a rock rundown. The energy of the runoff flowing over the headcut, particularly if the headcut is in a channel, can also be dissipated with a Zuni bowl. Ultimately the stabilization of a rill or gully that is incising can be achieved with a one rock dam which aims to armor and slightly aggrade the channel where soil is being lost.

If used in conjunction, many of these components can mitigate excess runoff and erosion in incised channels or degraded rangelands (Figure 7). These concepts are thoroughly reviewed as part of larger guides and videos to induced meandering and other land restoration techniques (3, 6, 7). Elements of these components, however, have also been adopted in more traditional GSI for the purposes of armoring inlets, pooling stormwater in sediment traps,



A headcut (foreground); eroding upslope, compromising topsoil and tree roots.



Exposed tree roots due to headcut erosion



Tree roots clinging to soil on a destabilized, non-vegetated hillside



Large pinon tree roots exposed on hillside due to erosion from weathering and lack of vegetation



Figure 6. Left to right: A media luna (photo courtesy of Minesh Bacrania), one rock dam, Zuni bowl, and rock rundown are structures used to mitigate stormwater runoff and erosion at low energy upland sites.

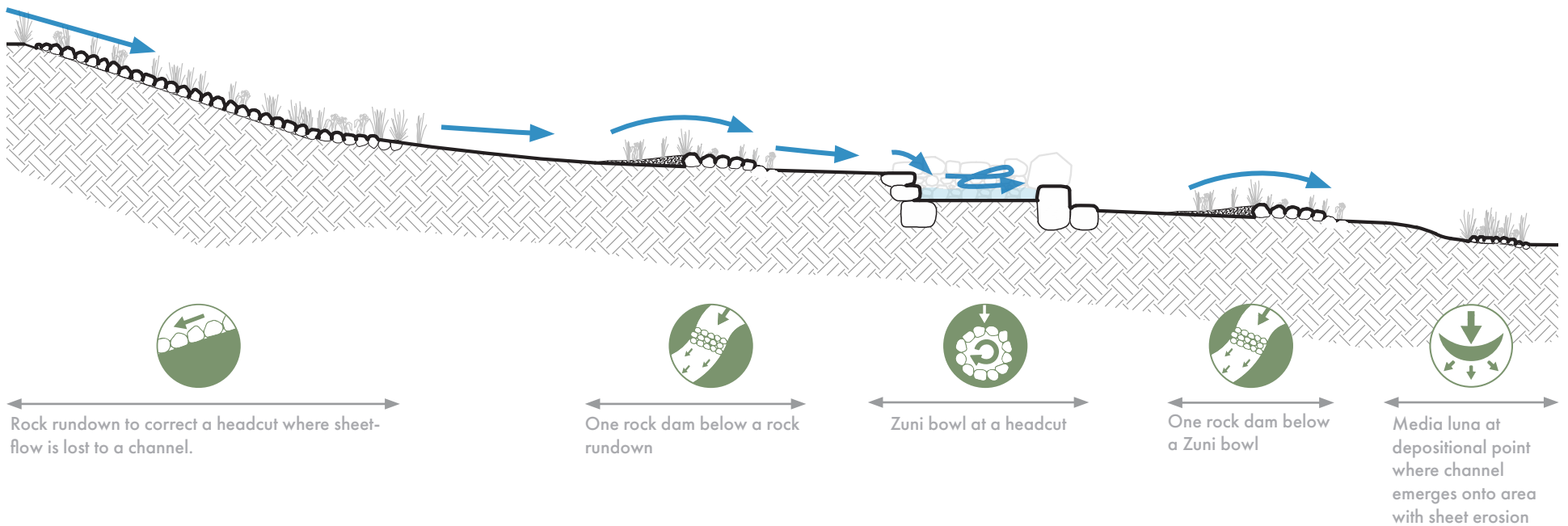

Figure 7. An example of how the four upland components could be used in conjunction to address the formation and degradation of a channel (e.g. headcut in a pasture that devolves into a gully). Although they can all be used in conjunction, as pictured here, this is not a common occurrence, and they are often used independently of each other.

MEDIA LUNA

DEFINITION

A PASSIVE WATER HARVESTING MULCH STRUCTURE INTENDED TO MANAGE SHEET FLOW AND SMALL HEADCUTS.

CRITICAL FEATURES AND PRINCIPLES

Use a tips up media luna to spread stormwater at a depositional area and a tips down media luna to collect sheet flow as it transitions into a rill or larger accumulation point.

CONSTRUCTION NOTES:

1. Identify the landscape contour and locate the structure ends so that flow cannot circumvent the structure.
2. Seed the area that is going to be mulched with stone.
3. Build from downslope moving upslope, keeping stones at approximately level height.
4. Consider embedding initial rows into the soil as a footer, especially if soil is bare, slopes are steep, or stone is particularly large and might cause a pour over point.
5. At sites with poor vegetation cover, place stone around grass pedestals.
6. The width of the structure should be at least 3ft. Increasing the width will expand soil moisture and strengthen the structure.



"Tips Down" Media Luna Upon Installation.

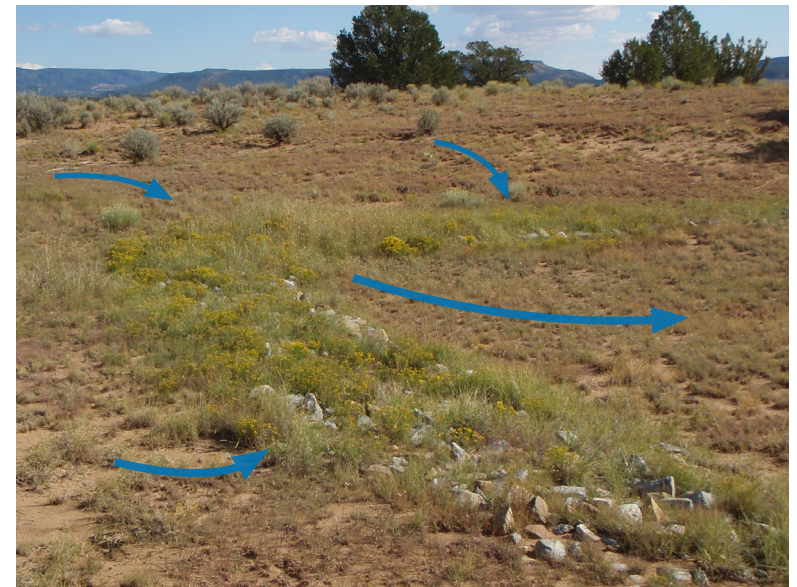

"Tips Down" Media Luna After Establishment (~ 1 year) (Image Credit: Craig Sponholtz).



KEYED NOTES:

- A. Stormwater moving off the surface carries seed and sediment. Media Luna traps it here.
- B. Rock (4-6") acts as a mulch to help slow, infiltrate, and prolong soil moisture. Sheetflow is concentrated below tips down media luna and accentuated below a tips up media luna.
- C. Footer rock to prevent erosive destabilization.

MAINTENANCE NOTES:

- 1) Inspect structure after initial storms to determine if any failure or damage occurred (e.g. stones displaced, erosion circumvented or piped through structure, etc.)

If so: Repair and reinforce with larger/more stone if necessary.

- 2) Assess whether other disturbances to the structure have occurred (e.g. livestock grazing newly germinated grasses).

If so: Consider a fence enclosure around the structure or moving animals until the structure's vegetation is established.

- 3) Ensure that seeds germinate or other vegetation colonizes the structure over time.

If so: Consider if reseeding or adding other vegetation will help strengthen the structure.

- 4) Determine if enhancing or adding more structures is appropriate.

If so: Lengthen or widen the Media Luna.

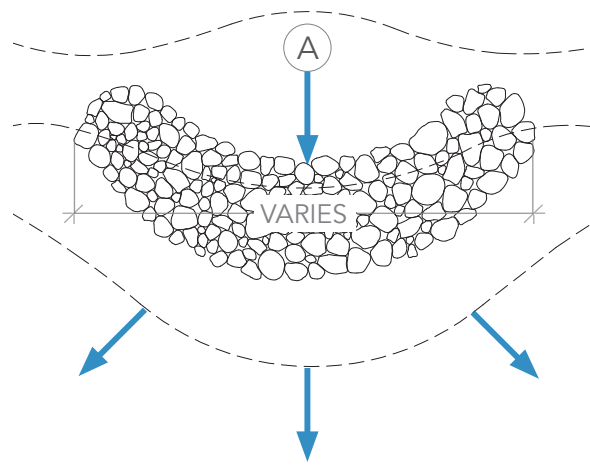

Plan Detail "Tips Up" Media Luna

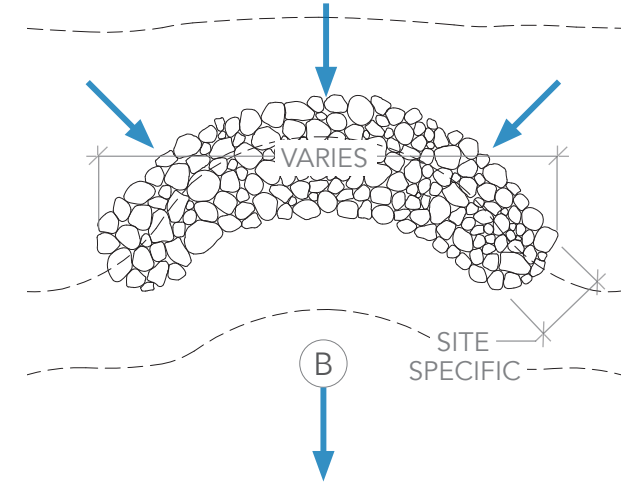

Plan Detail "Tips Down" Media Luna

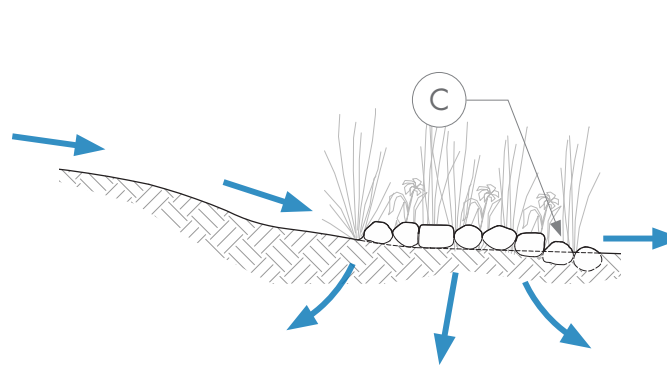

Section Detail "Tips Up" Media Luna

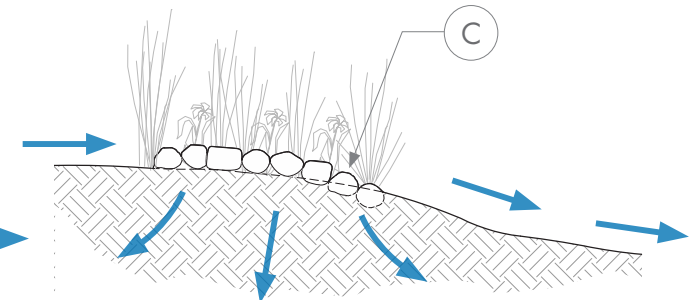

Section Detail "Tips Down" Media Luna

ONE ROCK DAM

DEFINITION

A GRADE CONTROL STRUCTURE— ONLY ONE ROCK HIGH— INTENDED TO STABILIZE THE BED OF A CHANNEL BY SLOWING FLOW, CAPTURING SEDIMENT, AND RECRUITING VEGETATION THROUGH PASSIVE WATER HARVESTING.

CRITICAL FEATURES AND PRINCIPLES

Should be built at the crossover (i.e. straight section of a channel) rather than the bend/curve in a channel.

CONSTRUCTION NOTES:

1. Select appropriate location (channel crossover) and stone size (1/3 of bankfull depth if apparent or stone that cannot be mobilized during flow events).

If built at a curve in the channel then flow might cut around structure on the outside bend.

2. Excavate splashpad footer for at least two rows of rocks. Footer stones should not protrude >2-inches above bed level. **Failure to embed lowest rows of rock results in scour at pour-over point and structure failure.** Toss excavated soil up channel so that it will flow into structure. Seed area prior to placing rocks above ground. Use grasses and wildflowers in drylands; rushes and sedges in wetlands.

3. Build structure from footer rocks, moving up channel (at least five rows), fitting stones together with increasing height. Maintain only one rock high with a concave shape through the middle. **Lack of concave shape might allow water to cut around bank edges.** Stones can be book-stacked to increase height.

4. Armor gaps with small stone and gravel.

5. Monitor for sedimentation, seed germination, or potential failure.

6. If the structure is stable and further aggradation (i.e. lifting the channel) is desired, then a second tier (i.e. one rock higher) can be added on top of the first structure. The first row of stone should begin halfway up original structure (i.e. the original structure is now the splash apron). Continue adding rows (at least five) beyond the top of the first structure.



Series of One Rock Dams at Crossover Points in Channel During Installation.



One Rock Dam at Channel Crossover.



KEYED NOTES:

- A. Footer/splashpad: sub-grade rocks buried downstream in shallow trench. (See construction note 2).
- B. Dam: one rock high. Placed upstream of footer rocks. (See construction note 3).
- C. Armor gaps with smaller stones to strengthen dam.
- D. Direction of water/channel flow.
- E. Concave shape maintained throughout middle of structure.
- F. Size of stones varies based on scale of project intervention.
- G. Pre-structure channel grade.
- H. Sediment deposited upstream raises level of the channel bed over time.
- I. Height of rocks above channel grade should be approximately 1/3 of the bankfull depth. Bankfull depth is described by Zeedyk & Clothier (2009) (see references).

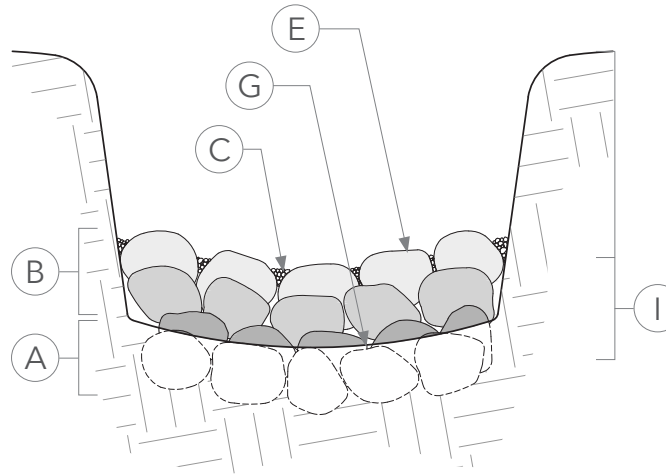

Front Section Detail One Rock Dam (Facing Upstream)

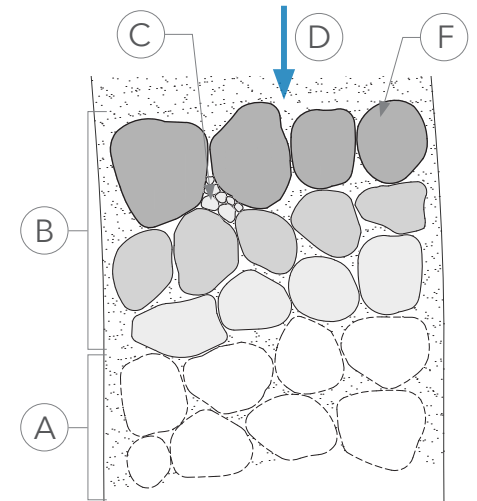

Plan Detail One Rock Dam

MAINTENANCE NOTES:

- 1) Inspect structure after initial storms to determine if any failure or damage occurred (e.g. stones displaced, erosion circumvented or piped through structure, etc.)
If so: Repair and reinforce with larger/more stone if necessary.
- 2) Assess whether other disturbances to the structure have occurred (e.g. livestock grazing newly germinated grasses).
If so: Consider a fence enclosure around the structure or moving animals until the structure's vegetation is established.
- 3) Ensure that seeds germinate or other vegetation colonizes the structure over time.
If not: Consider if reseeding or adding other vegetation will help strengthen the structure.
- 4) Determine if enhancing or adding more structures is appropriate.
If so: Lift elevation or add more one rock dams after initial structure has filled in with sediment (follow construction note 6).

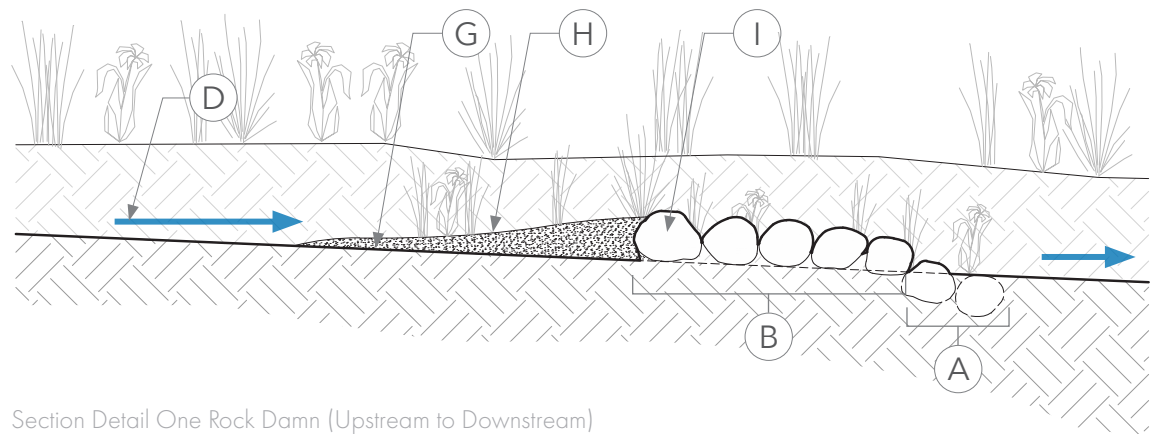

Section Detail One Rock Dam (Upstream to Downstream)

ROCK RUNDOWN

DEFINITION

A STRUCTURE INTENDED TO ELIMINATE A HEADCUT BY CONVERTING THE VERTICAL EDGE TO A MANAGEABLE GRADE ($\leq 3:1$ SLOPE) THAT CAN BE SUBSEQUENTLY ARMORED WITH A STONE MULCH TO REDUCE EROSION AND IMPROVE SOIL MOISTURE FOR VEGETATION.

CRITICAL FEATURES AND PRINCIPLES

Beneficial at a low energy headcut draining an area with sheetflow (e.g. pasture, wetland, etc.).

CONSTRUCTION NOTES:

1. Identify the headcut and consider the distance and amount of material that will need to be moved to create a 3:1 slope (i.e. 3 units of length for every 1 unit of height). Take care not to cut too much soil or disturb vegetation where flow will enter the structure.
2. Lay back the headcut to a 3:1 slope by cutting the top of the vertical face and utilizing the material as fill below. **Failure to maintain a concave shape through the middle of the structure might allow water to cut around edges. Concave shape will help to concentrate flow through center.** Narrow headcuts might need to be widened to place stone.
3. Compact the fill.
4. Seed the slope with appropriate grasses and forbs. Consider cool/warm season species, strong root structures (e.g. not cheat grass).
5. Identify the inflection point at the bottom of the slope and excavate a footer slightly down channel to serve as a splash apron.
6. Place stone from the bottom of the structure moving upslope until reaching the headcut pour over. **Ensure that no stones exceed the height of the pour over so that stormwater does not circumvent the structure.** Fill any gaps in the stone with small rocks and gravel.
7. If the rock rundown is in a channel, build a one rock dam down channel that exceeds the elevation of the splash apron.



Rock Rundown (Image Credit: Craig Sponholtz).



Rock Rundown.



KEYED NOTES:

- A. Headcut erosion.
- B. Headcut converted to 3:1 slope and covered with stone mulch.
- C. Inflection Point.
- D. Splash Apron.
- E. Seeded Vegetation Growth.

MAINTENANCE NOTES:

1) Inspect structure after initial storms to determine if any failure or damage occurred (e.g. stones displaced, erosion circumvented or piped through structure, etc.)

If so: Repair and reinforce with larger/more stone if necessary.

2) Assess whether other disturbances to the structure have occurred (e.g. livestock grazing newly germinated grasses).

If so: Consider a fence enclosure around the structure or moving animals until the structure's vegetation is established.

3) Ensure that seeds germinate or other vegetation colonizes the structure over time.

If not: Consider if reseeding or adding other vegetation will help strengthen the structure.

4) Determine if enhancing or adding more structures is appropriate.

If so: See construction note 7.

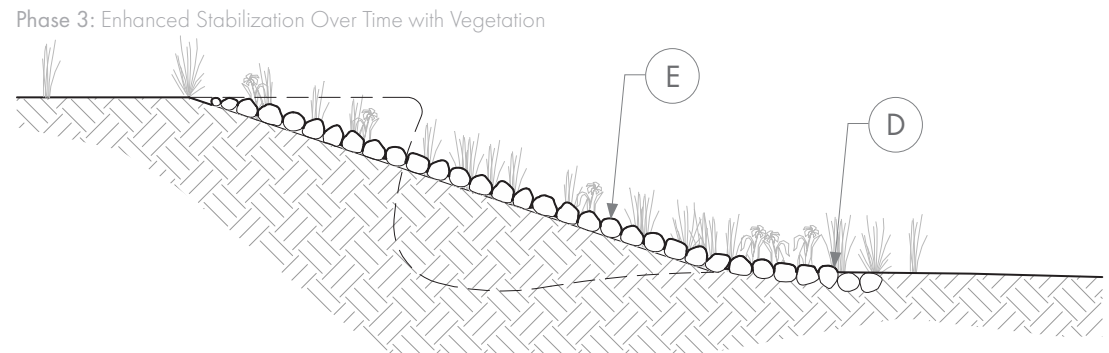
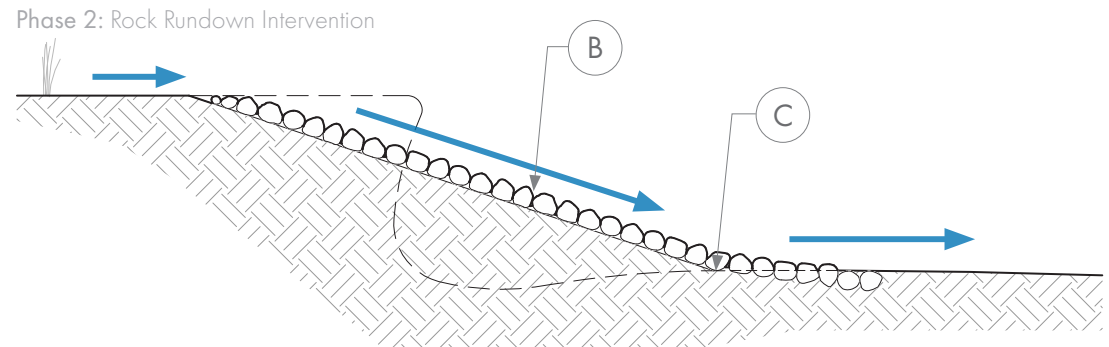
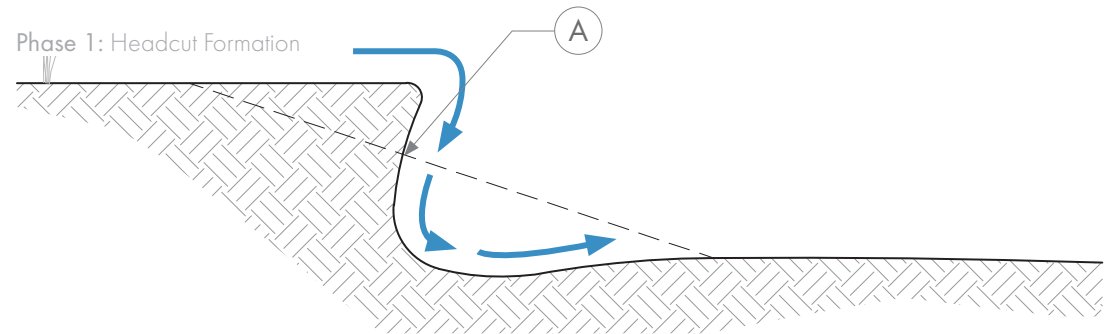

Section Detail Rock Rundown Phasing Over Time - Vegetal Growth

ZUNI BOWL

DEFINITION

A STRUCTURE INTENDED TO REMEDIATE A HEADCUT BY DISSIPATING FLOW ENERGY THROUGH ARMORED FALLS AND POOLS.

CRITICAL FEATURES AND PRINCIPLES

Zuni bowls are typically used as a BMP at in-channel headcuts in disturbed-soil areas where other structures such as rock rundowns might fail to fully reduce erosive scour. Zuni bowls can also be beneficial at reducing erosion near an elevated culvert outlet or where oxygenation of water is desired in intermittent or perennially flowing systems. This concept was developed in a collaborate effort between Bill Zeedyk and the people of the Zuni Pueblo, in which traditional indigenous erosion control practices were combined with modern restoration techniques. Zeedyk observed Zuni structures and adapted them into a bowl-shaped, rock-lined plunge pool specifically designed to manage headcut erosion. This concept has been further adapted to treat runoff from impervious surfaces in traditional GSI applications by utilizing a higher outlet or weir to lift and pool stormwater to greater depths as it moves through a basin. This adaptation, which is referred to as "Urban Zuni Bowl Modification" in this manual, is described in further detail on page 80 .

CONSTRUCTION NOTES:

1. Select a headcut for treatment, shape the headcut face for stone placement, and determine the structure dimensions (length = 3-4X the headcut height).
2. Excavate the footer and begin placing stones for the splash apron (level or only slightly protruding from the channel bed).
3. Utilize the largest rocks to begin forming the elevated lower pour over immediately upstream of the splash apron. Top of pourover should be 1/2 of inlet elevation..
4. Create a level course of stones upstream of the pour over that fit tightly against the channel edges and headcut face.
5. Add additional courses of stone—stepping outward so as not to create a vertical edge—against the channel edges and headcut face as needed.
6. Ensure that flow will pour over the structure and into the pool by not placing stone at a height that exceeds the headcut face.
7. Cobble can be added to the pool to further dissipate flow energy.
8. Build a one rock dam downstream (at a distance of 6-8X the height of the headcut) to reinforce the splash apron. (Not shown).



Zuni Bowl Under Construction.



Zuni Bowl Slowing and Stepping Stormwater Down-Slope from Impervious Parking Lot Surface.



KEYED NOTES:

- A. Constructed or natural channel.
- B. Inlet at former headcut pour-over.
- C. Plunge pool (with cobble if further mitigation of erosion/scour is needed).
- D. Boulder Size And Bowl Shape Varies Depending On Site Requirements.
- E. Outlet pour-over elevation is 1/2 height of headcut pour-over.
- F. Footer/splashpad: 1-2 rows of sub-grade rocks in shallow trench to stabilize structure and prevent scour. No rock should protrude more than 2" above the bed of the channel.

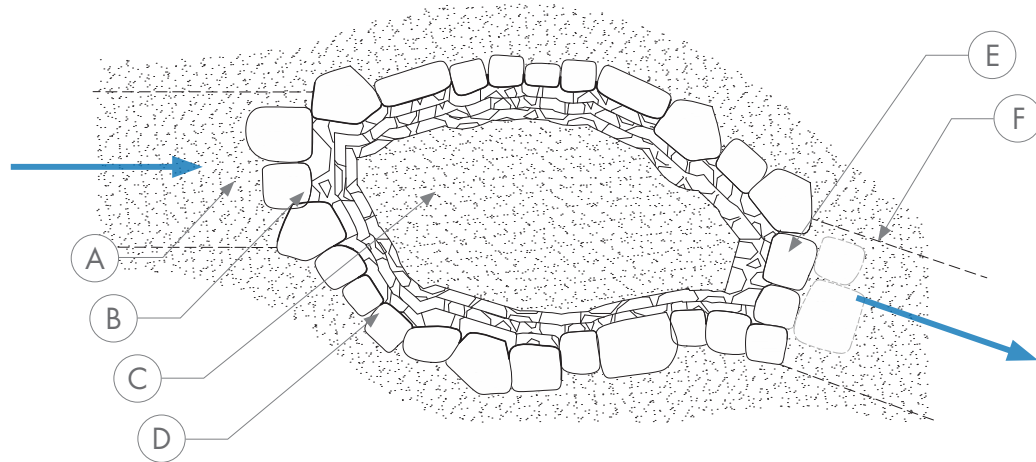

Rural Zuni Bowl Plan

MAINTENANCE NOTES:

- 1) Inspect structure after initial storms to determine if any failure or damage occurred (e.g. stones displaced, erosion circumvented or piped through structure, etc.)
If so: Repair and reinforce with larger/more stone if necessary.
- 2) Assess whether other disturbances to the structure have occurred (e.g. livestock grazing newly germinated grasses).
If so: Consider a fence enclosure around the structure or moving animals until the structure's vegetation is established.

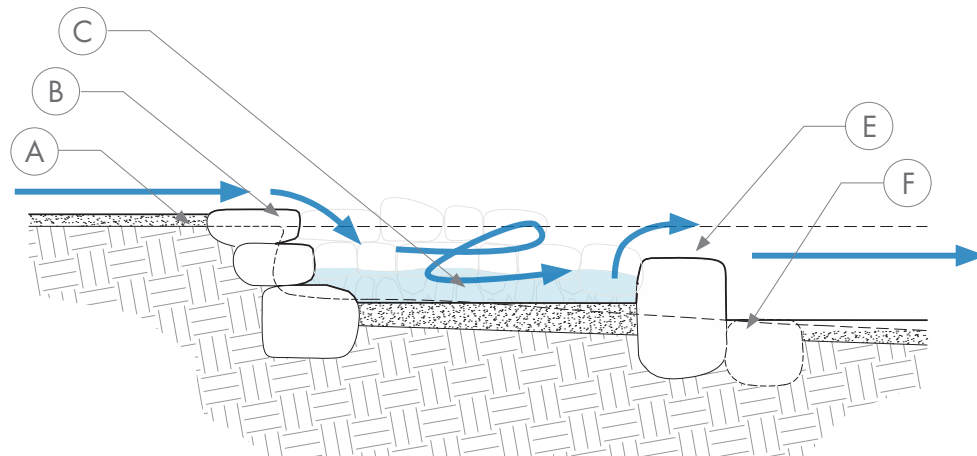

Rural Zuni Bowl Section

RUNOFF FROM ROOFTOPS

PASSIVE ROOFWATER CATCHMENT

Stormwater runoff from rooftops presents unique opportunities for catchment. Runoff can be reliably calculated due to well defined rooftop dimensions and is generally sediment free which minimizes treatment requirements prior to harvesting. Active harvesting in storage tanks allows for utilization between storms when soils dry out and plants need irrigation. The cost of tanks has risen significantly in recent years, however, and other expenses related to pumps, irrigation hoses and emitters, timers, etc. can make active catchment more prohibitive.

Passive storage of stormwater in soil is an excellent alternative to tank systems or as a point of overflow from cisterns. Canales, downspouts, and tank overflow pipes can be directed into open basins such as rain gardens, but in many situations around buildings there is insufficient surface area for broad, shallow GSI features. Pumice wicks can solve this problem by providing highly porous, subsurface cavities that direct stormwater into root zones.

Pumice wicks take stormwater from a roof and spread it evenly throughout the entire wick location. This is much different that a French drain, which is used to move excess water away from a structure or other foundation. Pumice wicks will eliminate erosion problems because the water is taken immediately off the roof and stored underground.



Major storm event overwhelming a rain barrel from roof runoff.

Pumice wicks can also be used to eliminate flooding issues because roof water can be routed away from the problem area. Most importantly, pumice wicks are an extremely efficient way to increase soil moisture reserves around an established planting area, or for any new future planting area. Once water is stored underground (pumice wicks are generally designed to store water within the first 18"-24" of soil where roots and microbes are most active) it becomes a fantastic resource for ecosystem establishment and soil health. In many cases, landscaped areas that utilize pumice wicks can be removed from supplemental irrigation.

KEYED NOTES:

- A. Canale (Roof Drain).
- B. Water pours out canale directly into catch basin below.
- C. Typical catchbasin detail.
- D. 2" - 4" River Rock.
- E. 4'-0" Diameter steel rimmed well lined with 2" - 4" round river rock over 9 mil. pond liner.
- F. 4" PVC (1/8"/foot slope) conveyance line bringing water from roof. Source pipe can drain into Pumice wick.
- G. 9" NDS (or equivalent) catchbox.
- H. Building.
- I. Rainchain.
- J. Downspout.

MAINTENANCE NOTES:

- 1) Keep roof free of debris, dirt, leaves, and twigs. These materials can get into the piping and cause blockage.
- 2) Ensure that the overflow pipe has positive drainage away from structures.



Flat roof to catchbasin.



Flat roof to catchbasin with rainchain.



Pitched roof with downspout to catchbasin.

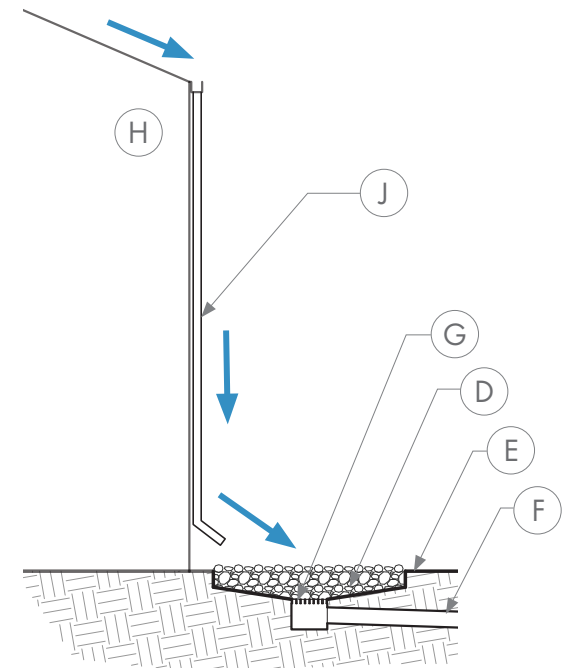
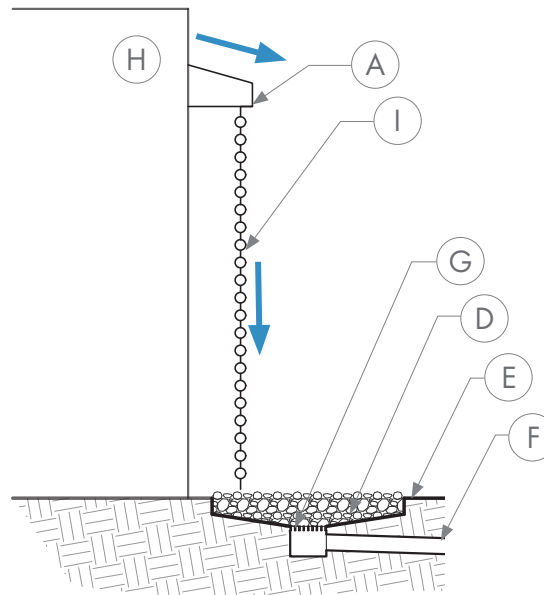
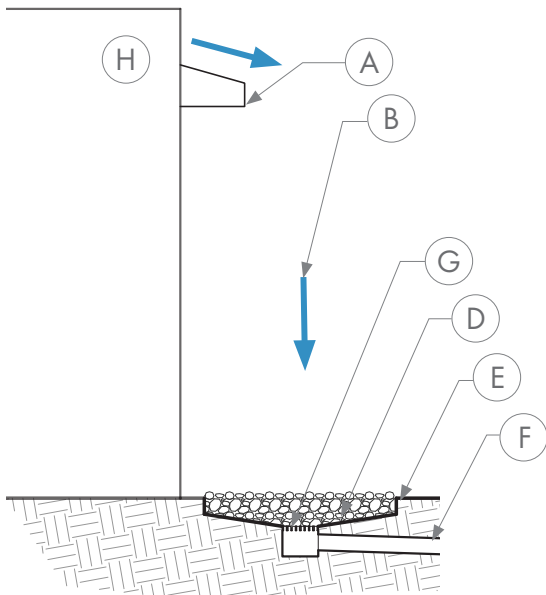

PUMICE WICK

DEFINITION

A HIGHLY POROUS SUBSTRATE (E.G. COBBLE WRAPPED IN GEOTEXTILE FABRIC OR WEED BARRIER) USED TO RAPIDLY INFILTRATE SEDIMENT-FREE STORMWATER (E.G. FROM A ROOFTOP) IN SOILS.

CRITICAL FEATURES AND PRINCIPLES

Pumice wicks are passive rainwater infiltration devices that store rainwater in the soils, preventing runoff and soil erosion from rooftop drainage. Pumice wicks are designed to infiltrate rainwater into the most biologically active soil layers (18") where an array of native plants, shrubs and trees can access the available moisture. Pumice wicks are also designed to spread water evenly through a large portion of the landscape, ensuring that moisture can be efficiently accessed by multiple areas and a variety of plant species. Pumice wicks store rainwater below the surface ensuring that evaporation is reduced and the moisture is accessible to plants and the landscape for many months after a rain event. All areas of landscape that have access to pumice wicks will need less irrigation water, and in many cases can be taken off irrigation completely.

COMMON IMPLEMENTATION MISTAKES

Failure to properly enclose the porous medium (e.g. cobble) with a filter fabric could allow sediment intrusion that reduces or eliminates subsurface water storage volume.

CONSTRUCTION NOTES:

1. Size of wick determined by area of roof and based upon a 1" storm event.
2. Sq. Ft of roof X .083 (1" rain) X 7.59 ft³ = gallons of water in a 1" rain event.
3. Identify space for new wick system. Wicks should be approximately 18" X 18" X length of trench (TBD depending on site). Pumice/Ascoria are approximately 50% air space.
4. Example: 1000 sq. ft. roof X .083 X 7.5 = 622.5 gallons. (A pumice wick that is 1.5' w X 1.5' D = 2.25 ft². 622.5 gallons ÷ 7.5 gallons/ft³ = 83 ft³. 83 ft³ ÷ 2.25 ft³ of pumice wick = 36.9 ft of open trench volume.) * Add 50% reduction in volume due to pumice/ascoria filling the trench in order to effectively capture and retain the entirety of the entire storm event, the trench will need to be double in length (i.e. ≈ 74 ft).
5. Conveyance. Rainwater from roof should be captured via downspout/gutters or catchment basins below a canale. Roof water is routed via 4" PVC (or NDS) to wick location. Conveyance piping should be installed at a minimum of 1/8" drop towards wick.
6. Excavate a trench that is approximately 18" wide, 18" deep and as long as the calculations for total storage *specify*. Excavated soils can be used as water harvesting berms on site or hauled off site.
7. Line the new trench with geotextile fabric to prevent root and soil blockage of spaces between pumice/ascoria.



Pumice Wick Trench, Unfilled.



Pumice Wick Trench, Filled.

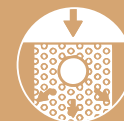

CONSTRUCTION NOTES (CONTINUED):

8. Fill the trench with pumice/ascoria leaving space for the 4" perforated pipe.
9. Connect perforated pipe (holes facing down) to conveyance piping and install perforated pipe at the top of the wick perfectly level.
10. Install the overflow pipe.
11. Cover the perforated pipe with pumice/ascoria and then fold geotextile fabric over the top of the entire wick.
12. Cover the wick with a minimum of 6" of soil.

KEYED NOTES:

- A. 4" Perforated pipe installed level.
- B. Grade.
- C. Overflow.
- D. Geotextile Fabric.
- E. 1" Pumice/Ascoria
- F. Pop-up overflow drain beyond.
- G. Soil and/or mulch.
- H. Source Pipe.

MAINTENANCE NOTES:

- 1) Keep roof free of debris, dirt, leaves, and twigs. These materials can get into the piping and cause blockage.
- 2) Ensure that the overflow pipe has positive drainage away from structures.

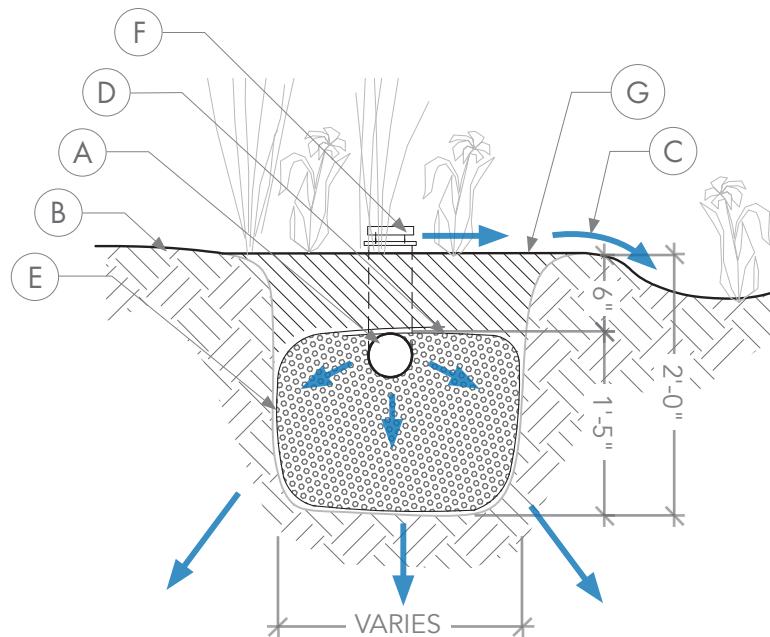

Cross section Through Pumice Wick

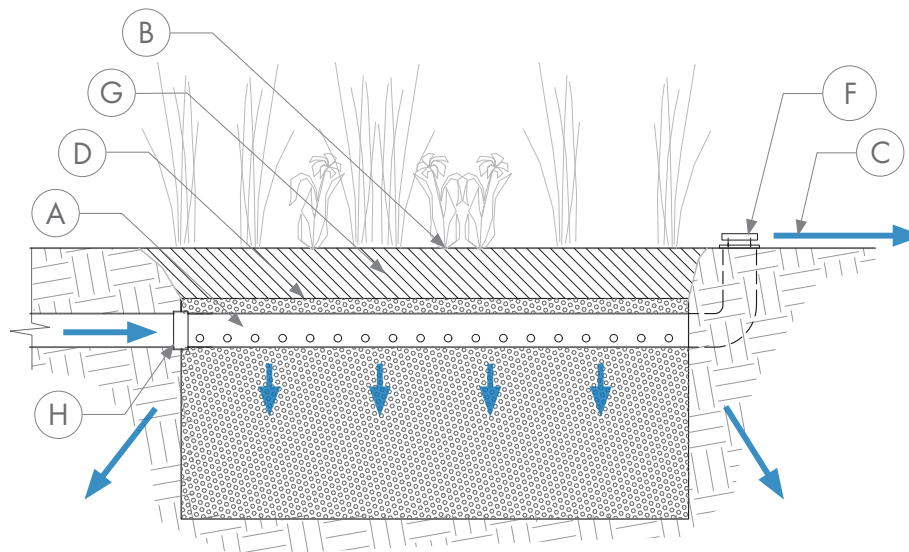

RUNOFF FROM IMPERVIOUS SURFACES

RUNOFF FROM IMPERVIOUS SURFACES

As municipalities are faced with growing stormwater management costs associated with flooding, communities are examining various options to address the problem. One overlooked, yet simplistic method to cut down on runoff is to reduce the extent of impermeable surfaces. Parking areas generally exceed the needs of drivers, and many municipalities are identifying opportunities to decrease the minimum number of parking spaces required by codes and ordinances (8).

If parking areas cannot be reduced, then a second option is to change the porosity of the parking surfaces themselves through permeable pavements. It should be noted that there are some regional complications and considerations regarding the use of permeable pavements in the Southwest. More details about the appropriate usage of permeable pavers as a GSI component in an overall systematic GSI design/plan can be found on pages 60–63 in this section.

Finally, the introduction of rain gardens, bioretention basins, and other systematic GSI features can help attenuate flooding by pooling and infiltrating stormwater close to where it falls. Installing and effectively utilizing these features as a solution to mitigate flooding issues from surface runoff can require the proper application, construction, and combination of unique GSI components. A review of appropriate GSI components and construction details can be found on the subsequent pages.



Standing water due to the absence of GSI in a parking lot.



Major storm event causing flooding in street and dangerous driving conditions.



Major storm event causing flooding in street due to lack of appropriate GSI.



Swirling vortex of water inundating residential street due to lack of GSI, which could instead be harnessed to irrigate surrounding vegetation and replenish the local aquifer below.



URBAN STORMWATER QUALITY

Stormwater management is currently gaining attention because environmental pollution continues to be a major concern in cities worldwide (1). In the United States, stormwater runoff from urbanization is second only to agriculture as the major cause of stream impairment (3). According to the New Mexico Economic Development Department, as of August 2025, over 65% of people live in an urban setting in Santa Fe County.

Urban stormwater runoff is considered one of the major non-point source contributor of pollutants released into the environment (4). Pollutants of concern include environmental toxins such as heavy metals, polycyclic aromatic hydrocarbons (PAHs), petroleum hydrocarbons, and chlorinated organic compounds such as pesticides and polychlorinated biphenyls (5,6). To complicate the matter, the materials used for the impermeable surfaces that carry the stormwater are also toxic. One good example of this is asphalt. Asphalt, being ubiquitous in our urban environments, is made of petroleum byproducts that are hydrophobic and easily translocated in an ecosystem via rainfall and stormwater movement. Asphalt in general lasts only 3–5 years before substantial degradation begins via weathering, exposure to electromagnetic radiation, and oxidation (5,6). Asphalt, including recycled asphalt, contains natural aggregate and bituminous asphalt, a material that contains heavy metals and PAHs (5,6,7). Heavy metals and PAHs are pollutants that have been identified as carcinogenic, mutagenic, and teratogenic (5,6).

When subjected to weathering, storm events, and freeze/thaw processes of a high steppe ecosystem, these heavy metals and PAHs leach out of the road base and infiltrate the water table, negatively impacting the quality of downstream and domestic water sources (7). Biotic pathogenic determinants are also found in stormwater, including fecal coliform and E. coli (8).

In addition, an excess and increased loading of nutrients in urban stormwater has resulted in the decline of species richness of algal, invertebrate, and fish communities in urban streams (9). In fact, the term “urban stream syndrome” has been coined by scientists studying the negative impact of urbanization to fresh water and stream ecosystems, which they describe as “the consistently observed ecological degradation of streams draining urban land” (7). As noted, stormwater carries pollutants into downstream watersheds. This includes the Rio Grande, to which the Santa Fe River is a tributary. Studies performed on the decline of federally endangered Rio Grande Silvery Minnow show an association between physical and hydrological changes in the Rio Grande River system (10). Bioindicators found in the Rio Grande have also shown that stressors are linked to multiple factors, including ammonia, heavy metals, bacteria and PAHs—indicating consistency with the known impacts of urban effluents (11).

Engineered drainage design routes and piping systems move water off impermeable surfaces quickly, leaving no ability for stormwater to infiltrate into the ground.

Conventional stormwater management includes retention ponds (1,3). Unfortunately, these retention ponds are large, often rock lined pits that have very limited biological activity and are ineffective as treatment solutions for pollutants (1,3). In fact, it has been shown that polycyclic hydrocarbons (PAHs) tend to accumulate in retention ponds, suggesting that these types of ponds actually attenuate this important class of pollutants (6). This accumulation of PAHs tends to create a hydrophobic film in the retention basins, clogging the soil matrix by adsorbing onto soil particles, making it even more difficult for the infiltration of stormwater (6).

In November of 2021, in collaboration with the NMSBA and Sandia National Laboratories, The RainCatcher Inc. sampled 8 different locations around the Santa Fe area for the ‘first flush’ of stormwater flowing to retention basins. Results indicated that phthalates and PAHs were collected in the water samples. Although the concentrations were extremely low, this was a preliminary proof of concept that these molecules are in urban stormwater runoff located in Santa Fe County. Upon further investigation, in December of 2023, again with collaboration with NMSBA and Sandia National Laboratories, The RainCatcher Inc. set forth to test the soils in 14 locations in retention basins within Santa Fe County. Using a technique called VASE (Vacuum Assisted Sorbent Extraction) in collaboration with thermal desorption gas chromatography/mass spectrometry, it was demonstrated that a complex suite of VOCs/SVOCs (volatile to semi-volatile organic compounds) were present.

VASE elucidated in soil/water samples using VASE-GC/MS with only a small amount of sample material (~1 g) and without the use of extraction solvents needed in other established analytical methods. The range of compounds readily detected using this technique was surprisingly wide, ranging from low molecular weight volatiles such as dimethyl sulfide (CH₃)₂S /BP 37 °C up to octacosane (C₂₈ H₅₈/ BP 435.6 °C), as well as PAHs (polyaromatic hydrocarbons) comprised of up to 4 rings.

This represents a range of detectability into which a wide breadth of known anthropogenic pollutants (e.g., petroleum-based byproducts) would fall. In this study, a fairly comprehensive inventory of the compounds detected in each sample is provided. Unsurprisingly, the samples exhibited extraordinarily complex chemical profiles with more than 650 distinct compounds identified in the sample set.



Petroleum-based pollutants including PAHs and microplastics clearly shown in stormwater runoff.



An example of trash carried by stormwater runoff collecting in a storm drain.

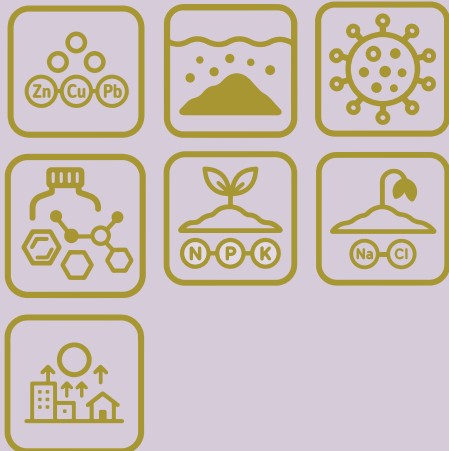

For more information on common pollutants found in stormwater, see page 8-9.

PERMEABLE PAVEMENTS

PERMEABLE PAVEMENTS

There are several common types of permeable pavements including porous asphalt (PA), pervious concrete (PC), permeable interlocking pavers (PICP), concrete grid pavers (CGP), and plastic reinforcing grids (PRG) (Figure 8). PA and PC are poured and cured in place without finer particulates common to conventional concrete or asphalt. The absence of finer particles creates pore space that allows for infiltration through the surface. PICP, CGP, and PRG are cast in advance with varying degrees of surface porosity ranging from narrow linear gaps between pavers to large geometric voids filled with coarse textured soil such as pea gravel. Each pavement type requires coarse substrates that provide additional porosity to allow stormwater to permeate to deeper

layers. Studies have found that permeable pavements are initially capable of very high infiltration rates due to porous surfaces. Some industrial manufacturers boast infiltration rates of 100 inches/hour, a rate far surpassing typical soil textures. This infiltration rate is dependent upon deep underlying coarse sublayers to the permeable pavers. In semiarid and arid climates with poor ground cover however, high sediment loads from soil erosion, dirt roads, deicing cinders, and dust can rapidly plug the porous surfaces and underlying textures in these permeable hardscapes (Figure 9). Without regular maintenance, including from vehicles with high-powered vacuum systems, the high infiltration rates of permeable pavements can decline rapidly. Other limitations to permeable

considering are pedestrian access that meets ADA compliance and the reduced surface strength capable of withstanding conventional vehicle traffic volumes or extreme loads (9).

Utilizing permeable pavements can still have value in sediment deprived areas such as sidewalks, patios, and driveways. Permeable pavements should also be considered in small areas where stormwater basins cannot fit or where sediment is regularly managed. Ideally permeable pavements used for roadways and parking lots would also have GSI features with pooling areas in the event that hard surfaces are unmaintained (Figure 9). For the purposes of this manual, only PICP and CGP are considered in the diagram section.

(Figure 10)



Figure 8. Concrete grid paver (left), permeable interlocking pavers (right), and plastic reinforcing grids are three forms of permeable pavers that include porous gaps to increase infiltration of stormwater to porous substrates.



Figure 9. Examples of how unmaintained permeable pavers can lose infiltration capacity due to fine textures plugging the porous gaps (left and middle) which results in standing water on the surface (right).



Figure 10. Example of concrete grid paver driveway with minimal sediment sources (left) and permeable interlocking pavers with curb cuts (right) which could direct excess stormwater into other GSI features such as rain gardens (not shown).

PERMEABLE PAVEMENTS

DEFINITION

A POROUS ALTERNATIVE TO CONCRETE, ASPHALT, AND OTHER IMPERMEABLE SURFACES THAT IS INTENDED TO FACILITATE INCREASED STORMWATER INFILTRATION ON SIDEWALKS, ROADS, AND PARKING LOTS.

CRITICAL FEATURES AND PRINCIPLES

Studies have found that permeable pavements are capable of very high infiltration rates due to porous surfaces and underlying substrates. In semiarid and arid climates with poor ground cover however, high sediment loads from soil erosion, deicing cinders, and dust can rapidly plug the porous surfaces and underlying textures in these permeable hardscapes. Without regular maintenance from vehicles with high-powered vacuum systems, the longevity of permeable pavements can decline rapidly. Utilizing permeable pavements can still have value in sediment deprived areas such as sidewalks, patios, driveways or small areas where stormwater basins cannot fit. Ideally permeable pavements used for roadways and parking lots would also have GSI pooling areas in the event that hard surfaces are unmaintained.

COMMON IMPLEMENTATION MISTAKES:

Insufficient porous substrate for water infiltration/storage. Unavailability of vacuum truck or other equipment for proper maintenance.

CONSTRUCTION NOTES:

1. Install according to manufacturer details.



Concrete Grid Pavers (CGP)

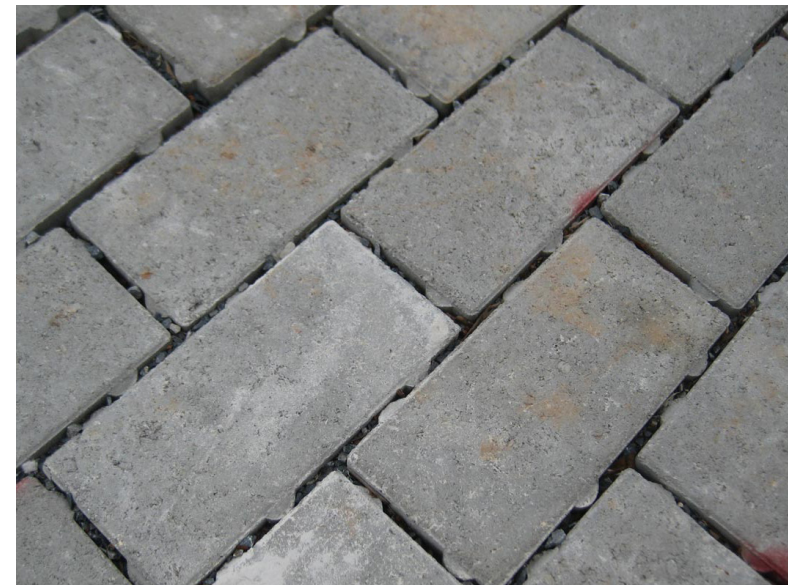

Permeable Interlocking Concrete Pavers (PICP) *(Image Credit: Homeguide.com)*
In ideal style for Southwestern regions. Staggered ridges in between gaps prevent shifting that may block openings. Wider [than standard] gaps increase filtration potential and mitigate sediment build up in arid climates.



KEYED NOTES:

A. Permeable pavement surface material. From left to right: porous asphalt, pervious concrete, concrete paver. 3 1/8" thick minimum for vehicular traffic. 2 3/8" thick acceptable for pedestrian and residential applications. [Surface material thicknesses will vary based on material properties and traffic loading. The thickness of PICP is typically 3 to 3.5 inches (in). PA is typically 3 to 6 in, PC is typically 4 to 8 in, and PP are typically 2 to 4 in.]

B. 1–2" thick bedding course (typ. size 8 aggregate). Only necessary under permeable pavers. [Typ. No. 8 or 89 stone coarse (3/64 to 3/8 in)]. [With PICP or CGP, the bedding coarse aggregate will be used to fill the voids within the pavement to the surface.]

C. 3–6" open-graded choker coarse [to block the void openings at the top of the reservoir coarse]. [Typ. ASTM No. 57 size stone (3/16 to 1 in)]. Only necessary under porous asphalt and pervious concrete surface materials.

D. 4" thick size 57 stone open-graded base coarse [to function as the reservoir for a permeable pavement system]. [Typ. ASTM No. 2 or No. 3 stone (1 to 2.5 in)]. [While these are frequently a single layer, they may also be separate layers with a base coarse overlying a subbase reservoir]. [The thickness of this layer is determined by the structural or hydrologic design of the system.]

E. Min 6"/12" thick open-graded stone subbase reservoir [Typ. No. 2 size stone].

F. Drainage geotextile on sides of subbase and under curb. Although a geotextile is not required between the reservoir coarse and the subgrade soil, it can improve structural stability of the profile by preventing migration of aggregate into surrounding soil. This geotextile should extend up the sides of the system to the pavement surface.

G. Optional drainage geotextile on subgrade per design engineer.

H. Uncompacted subgrade soil – zero slope.

I. 1/8" gap between joints filled with crushed gravel. Larger gaps are preferable in arid regions like New Mexico to promote enhanced drainage and prevent gaps from clogging with sediment as easily/quickly.

J. Standard concrete curb.

K. Sidewalk or other adjacent surface.

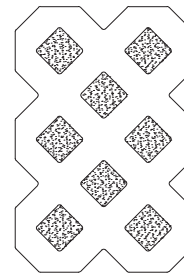

Plan detail of individual CGP

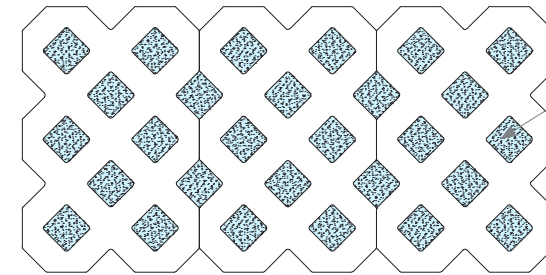

Plan detail of CGPs assembled in interlocking group

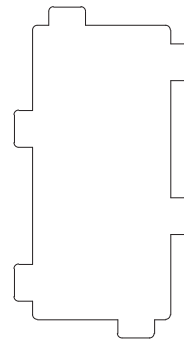

Plan detail of individual PICP

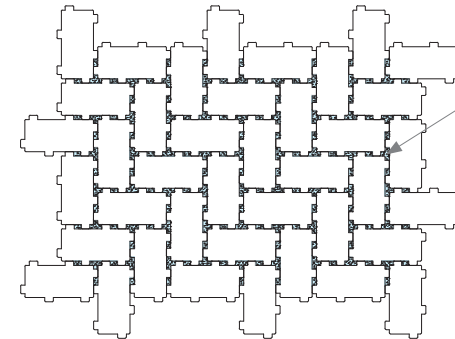

Plan detail of PICPs assembled in interlocking group

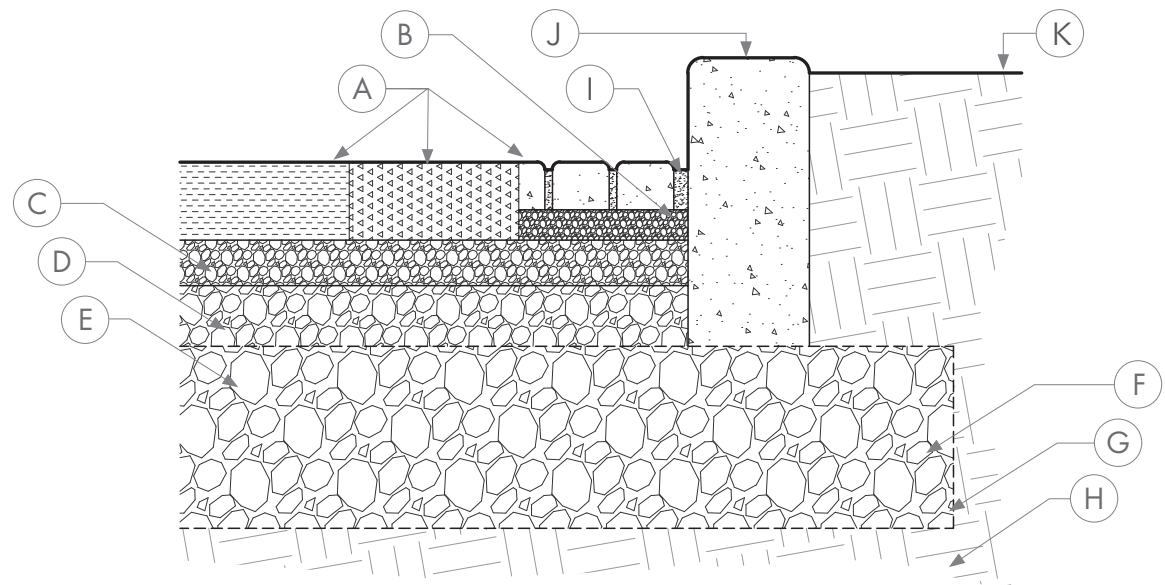

Section through permeable pavement types and underlying substrates

DEFLECTORS / DRAIN CAPS

DEFLECTOR OR DRAIN CAPS

Deflecting runoff can be critical in low flow situations where a fraction of an inch in elevation or grade could mean the difference in thousands of gallons of stormwater accessing or missing inlets to GSI features. In some cases, a small cement baffle in a gutter bottom is sufficient to push stormwater during low flows into a GSI feature; at other times, an asphalt or plastic/rubber molded speed bump might be necessary to direct stormwater across a larger surface area into a basin (Figure 11). In rural areas with dirt roads, a rolling dip can be used to efficiently drain runoff and passively irrigate adjacent pasture or woodlands (14). On impervious asphalt roads, more extreme measures to redirect runoff might be necessary, such as storm drain caps (Figure 12). Gutters on pitched metal roofs and caps on roof canals to direct stormwater into downspouts can also be thought of as deflectors.



Figure 12. Covering a drain can help “daylight” stormwater so that it continues to flow above ground (instead of a darkened, below ground pipe) to a point of catchment. An estimate of increased discharge should be considered before installing a drain cap to ensure that daylighted runoff will not cause flooding, erosion, or other problems prior to reaching a GSI feature where stormwater is intended to be captured.



Figure 11. Examples of cement gutter (left and right) and asphalt speed bump deflectors redirecting stormwater into rain garden inlets.



Correct layout of the speed bump deflector is when it is installed at an angle to contours, allowing stormwater to shed from impervious surfaces into the adjacent rain garden inlet.



Incorrect layout of the speed bump deflector is when it is installed on contour, causing stormwater to pool instead of shed from the impervious surface into the rain garden inlet. Pooling against the speed bump could deteriorate asphalt and cause slippery conditions (ice formation) in winter.

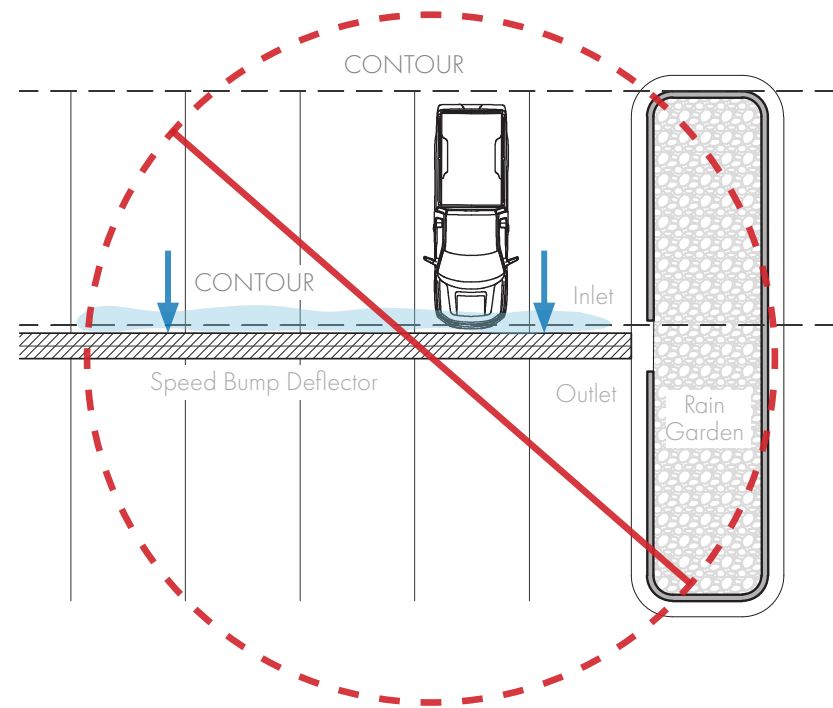
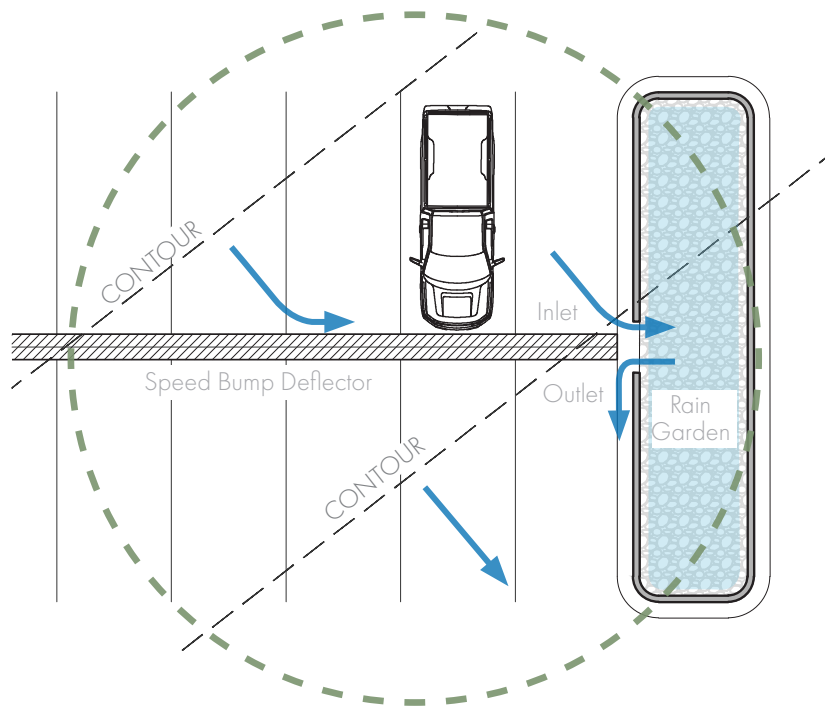

Correct vs. Incorrect Layout of Speed Bump Deflectors in Parking Areas

Diagram depicting the correct and incorrect layout and installation of asphalt speed bump deflectors to ensure optimum stormwater infiltration into rain garden inlets when installed in a parking area with impermeable surfaces. See Construction Notes on the following page for further details (Pg 68).

DEFLECTORS

DEFINITION

A RAISED OBSTACLE OR DEPRESSION THAT CAN BE USED TO REDIRECT FLOW TOWARD AN INLET OR SOME OTHER POINT WHERE STORMWATER CAN BE MORE EASILY HARVESTED AND TREATED.

CRITICAL FEATURES AND PRINCIPLES

Different types of deflectors can be used depending on the location/desired destination and size of the area of runoff that needs to be intercepted. Smaller concrete/cement deflectors are useful in gutters, while larger deflectors, like speed bumps, are useful in situations where stormwater needs to be conveyed across a larger area, such as across a parking lot. Locating where a deflector should be installed is best done during low intensity storm events or snow melt in order to identify imperfections in impervious elevation and avoid the potential for puddles or standing water.

CONSTRUCTION NOTES:

Gutter Deflector:

1. Mix cement (use Portland cement with a sand mix—not gravel) with water according to cement details and apply to a dust free and slightly moist surface in the gutter.
2. Apply up to 2" elevation of cement near the curb edge and taper down to the gutter surface near the GSI inlet opening. The width of the cement baffle should be 6"-12" and taper up and down at the gutter elevation (i.e. ramp up and down rather than have a vertical edge).

Speed Bump Deflector:

1. Consult with appropriate traffic guidelines and ordinances prior to installing a speed bump at sites with speed limits > 15 mph.
2. Speed bumps used to deflect stormwater in low speed traffic areas should generally be oriented perpendicular to vehicle movement.
3. Speed bump deflectors must not be on contour or stormwater could pool/puddle against the impediment instead of shedding off the impervious surface.
4. Install asphalt or rubber/plastic speed bump according to manufacturer or contractor details.



Cement Deflector Directing Stormwater Runoff into Parking Space Retrofit.



Speed Bump Deflector In Rain Directing Stormwater Runoff into Curbside Rain Garden.



KEYED NOTES:

- A. Bolt
- B. Standard 6" curb
- C. Inlet opening
- D. Concrete Deflector
- E. Rubber Deflector with striping

MAINTENANCE NOTES:

- A. Assess during low flow events to ensure stormwater is directed into basin.
- B. Assess during high intensity events to ensure that flow is not exceeding curbs or causing unwanted erosion.
- C. Correct elevations or orientation if undesired flow or puddles are created.

CONCRETE DEFLECTOR:

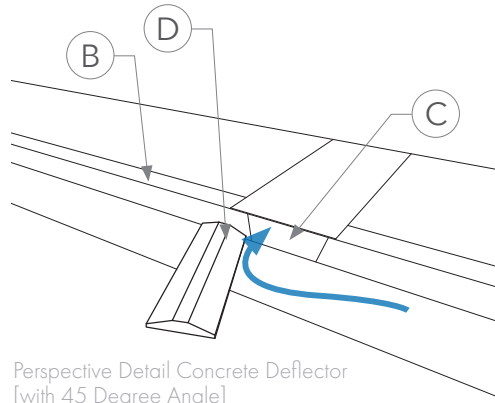

Perspective Detail Concrete Deflector
[with 45 Degree Angle]

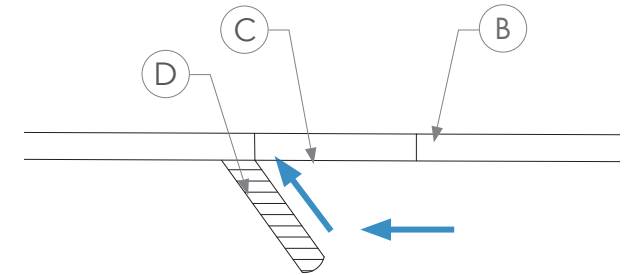

Plan Detail Concrete Deflector

BAFFLE CONCRETE DEFLECTOR:

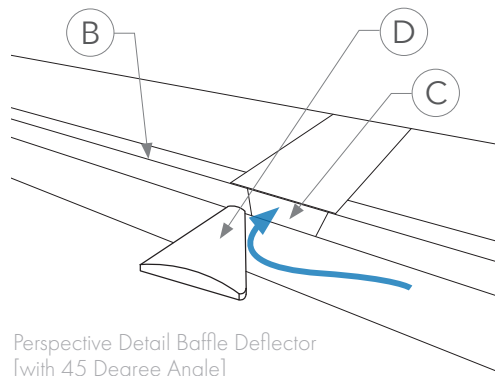

Perspective Detail Baffle Deflector
[with 45 Degree Angle]

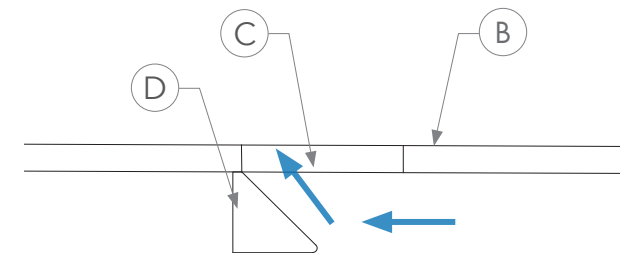

Plan Detail Baffle Deflector

SPEED BUMP DEFLECTOR:

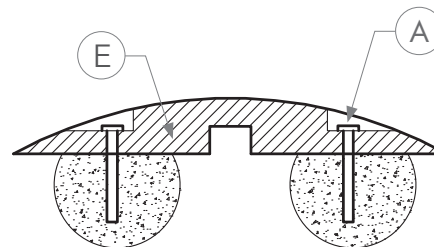

Section Detail Speed Bump Deflector

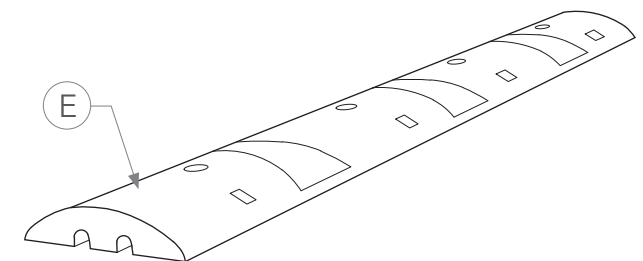

Perspective Detail Speed Bump Deflector

DRAIN CAPS

DEFINITION

AN IMPEDIMENT TO DRAINAGE THAT CAN BE USED TO REDIRECT FLOW TOWARD AN INLET OR SOME OTHER POINT WHERE STORMWATER CAN BE MORE EASILY HARVESTED AND TREATED.

CRITICAL FEATURES AND PRINCIPLES

Drain caps are a type of deflector that block off all or part of an existing storm drain to maintain stormwater runoff above ground where it can be conveyed downslope to a GSI catchment system to provide natural filtration, better infiltration, and passive irrigation to vegetation without supplemental irrigation. If flooding is a concern, drains can be half-capped to daylight stormwater during smaller storms while retaining the ability to drain overflow to the municipal stormwater system during larger storms.

COMMON IMPLEMENTATION MISTAKES

An estimate of increased drainage area and discharge (i.e. ft^3/sec) should be considered before capping a storm drain to ensure that extra runoff will not cause flooding, erosion, or other problems prior to reaching a GSI feature where stormwater is intended to be captured.

CONSTRUCTION NOTES:

1. Temporarily remove the existing drain.
2. Place premeasured and predrilled 1/4-inch thick steel sheet cap on top of the drain.
3. Place four Grade 8 1/2-inch diameter carriage bolts through the predrilled holes beyond the existing metal drain slots.
4. Add a washer with a diameter greater than the drain slot and secured with a lock washer and Grade 8 nut.
5. Two slots pre-cut in the metal plate should allow for future drain removal with a chain
6. Replace the drain and cap in the gutter. The slots intended for drain removal can be sealed with a piece of rubber or other material to prevent stormwater from entering.



Drain cap showing how the omission of half its possible area (i.e. red dotted line) would redirect flow during smaller storm events, but drain larger runoff events.



Fully Fitted Drain Cap.



KEYED NOTES:

- A. Existing storm drain.
- B. 1/4" thick steel cap.
- C. Four grade 8-1/2" diameter carriage bolts.
- D. Existing metal drain slots.
- E. 2 slots cut in metal cap to allow for future drain removal with a chain. Slots should be filled with foam or rubber and sealed with silicon to prevent water from entering.
- F. Low flow.
- G. Washer.
- H. Lock washer.
- I. Grade 8 nut.
- J. High Flow.

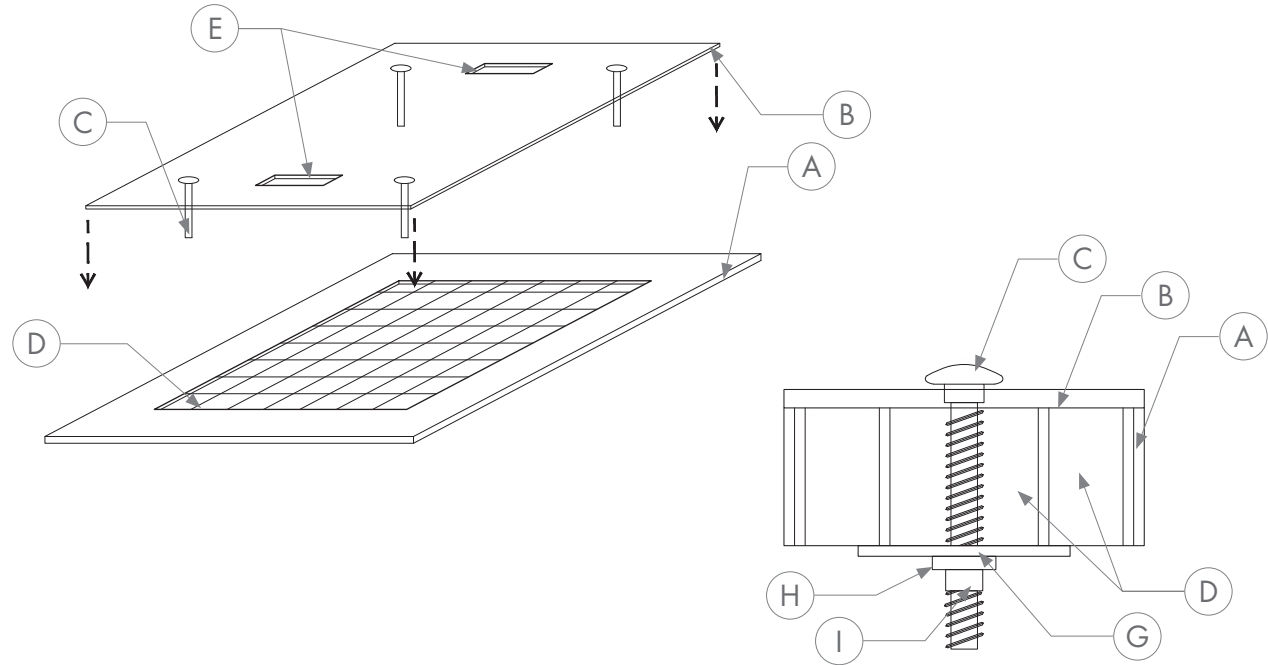

MAINTENANCE NOTES:

1) Periodically inspect during and after storm events to ensure that flooding or erosion problems have not been created as a result of the drain cap.

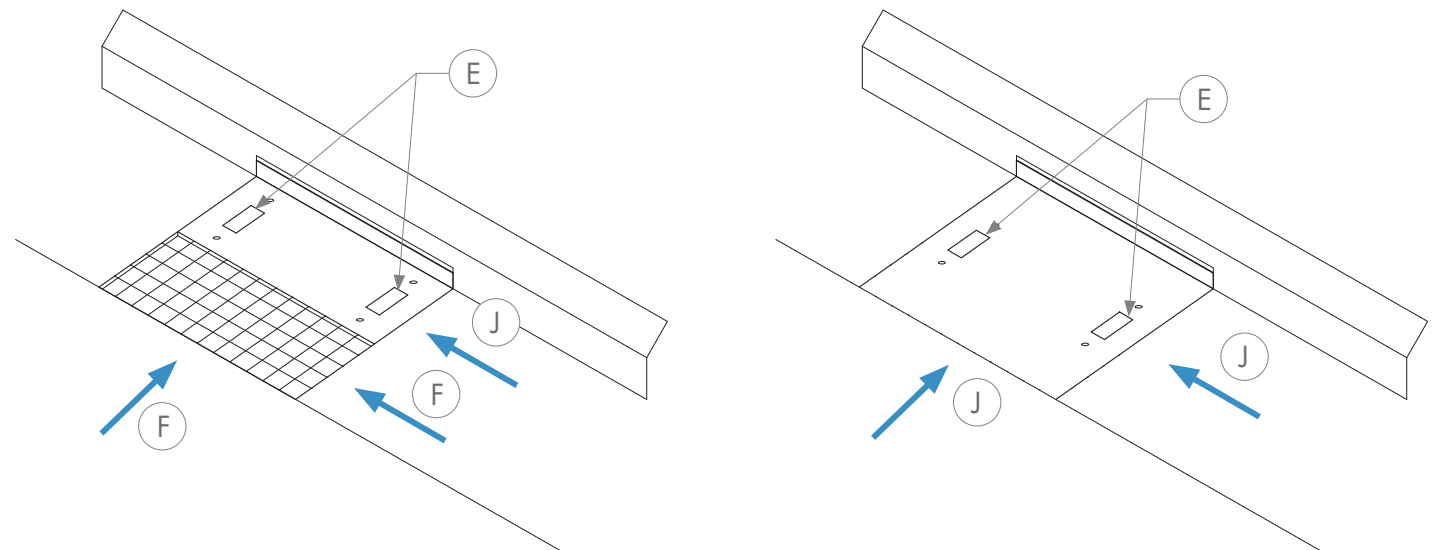

INLETS

INLETS

Stormwater inlets will vary by diameter and frequency depending on the conditions and size of the area contributing runoff. Curb cores, curb cuts, and curbs flush/level with the gutter elevation are methods to draw stormwater into a GSI feature. There are advantages and disadvantages to each. Cores maintain an intact curb for safety, but are more prone to plugging with sediment and are inefficient at diverting water that is not flowing perpendicular to the opening. Flush curbs will maximize stormwater inflow, but lack safety controls to keep vehicles from entering a basin. A curb that is flush with the gutter over a larger distance also makes the concentration and maintenance of sediment more challenging. Curb cuts are the most common and easiest inlets to design and maintain, with dimension widths influencing sediment transport and efficiency of water entering a basin. Examples of different curb openings can be found in Figures 13-15.

A curb cut or other inlet must be installed at a collection point (i.e. low point) in the area of contributing runoff. Typically this is a gutter where stormwater has been drained towards. If a gutter or other inlet site is not in the path of flow or exceeds the elevation of the source of runoff (i.e. stormwater will not flow upslope), then deflectors to redirect flow, drains to harvest and convey stormwater, or the relocation of the inlet must be considered. Direction and discharge of flow, sediment loads, slope, and diameter will all influence the effectiveness of an inlet at collecting stormwater. Broader (>2 ft long) curb cuts are probably best where stormwater is flowing parallel to the opening or from larger (>5,000sqft)



Figure 13. Numerous curb inlets along a median edge might promote better stormwater catchment than a singular opening. Extra curb cut openings are good where maximizing inflow is desired, where unevenness of gutter or adjacent impervious areas might require multiple inlets, or to prevent pooling water on parking areas if the curb is on contour (i.e. minimal slope).captured.

areas of impervious surface. Moderate (1ft-2ft) cuts will function if stormwater is flowing perpendicular towards a curb opening or from smaller impervious areas. Gaps less than 1 ft, including curb cores, should be avoided due to the likelihood of sediment buildup over time. Small curb cuts can also constrict stormwater during high intensity events or from larger areas of runoff which can cause runoff to jump curbs. Pipes and drains can be useful where pedestrian access or intact curbs are needed for vehicle deterrence.



Figure 14. Curb cores (left) maintain the integrity of a curb, but are more prone to plugging with sediment and therefore not generally recommended. Flush curbs (middle) can maximize inflow, but fail to concentrate sediment at a point where it can be managed. Flush curbs might also necessitate the introduction of boulders or vertical core-filled metal pipes to prevent vehicles from damaging vegetation/soil. Moderate (18-24 inches wide) curb openings (right) are ideal for concentrating catchment at a defined point where sediment traps can be installed.



Figure 15. The width of a stormwater inlet for comparable areas of runoff might vary depending on the direction of flow at the capture point. If stormwater is running perpendicular to flow (left), then a smaller opening might suffice. If stormwater is running parallel to the inlet and must make a 90 degree turn into the basin from a small area of runoff (middle), then the inlet width could be improved with a small deflector. As the area of runoff increases, if stormwater is running parallel to the inlet, then a much wider inlet with steeper slope might be required (right). Note that during high intensity storms, runoff in the photo to the right can still bypass the inlet due to originating from approximately 20,000sqft of asphalt area.

INLETS

DEFINITION

A POINT OF ENTRY FOR RUNOFF INTO A GSI FEATURE INTENDED TO SLOW, INFILTRATE, AND/OR TREAT STORMWATER.

CRITICAL FEATURES AND PRINCIPLES

Inlet opening should never exceed the outlet opening (*does not apply if the two components share the same opening*) or stormwater could exceed GSI features. Inlet must be installed at a collection point. Deflectors must be used in conjunction with inlet to direct path of stormwater if inlet is not installed in the path of the flow.

COMMON IMPLEMENTATION MISTAKES

Avoid installing a curb cut inlet at the lowest point in a median (i.e. this would serve as an outlet) or at a point along a curb that stormwater does not flow towards. Inlets with insufficient width commonly plug with sediment/debris or fail to maximize inflow of stormwater.

CONSTRUCTION NOTES:

Curb Cut Inlet

1. Secure a curb cut permit if required by local codes/ordinances.
2. Use a concrete saw with a blade diameter of at least 14".
3. Cut the two ends of the inlet width ensuring that the blade reaches down to the gutter elevation.
4. Make similar cuts every 2"-4" between the two initial cuts.
5. Use a mallet or large hammer to break and remove the 2"-4" pieces.
6. Grind down any remaining pieces at the gutter elevation to ensure that stormwater easily enters the inlet.
7. If the concrete saw blade can be tilted and is long enough, cut 45° angles at the curb cut inlet edges to reduce the vertical edge.



Curb Cut Inlet with Deflector.



Wide Curb Cut Inlet with Armored Sides to Capture Flow Running Parallel to Opening.



KEYED NOTES:

- A. Standard 18" gutter width.
- B. Standard 6" high X 6" wide curb.
- C. Inlet width can vary depending on flow of stormwater and area of runoff.
- D. OPTIONAL: Concrete apron can be included during construction of new inlet to minimize scour at back of curb.
- E. 45° angle cut.

MAINTENANCE NOTES:

- 1). Periodically assess inlet condition for impediments to flow, erosion, or other hazards. Correct issues if present.

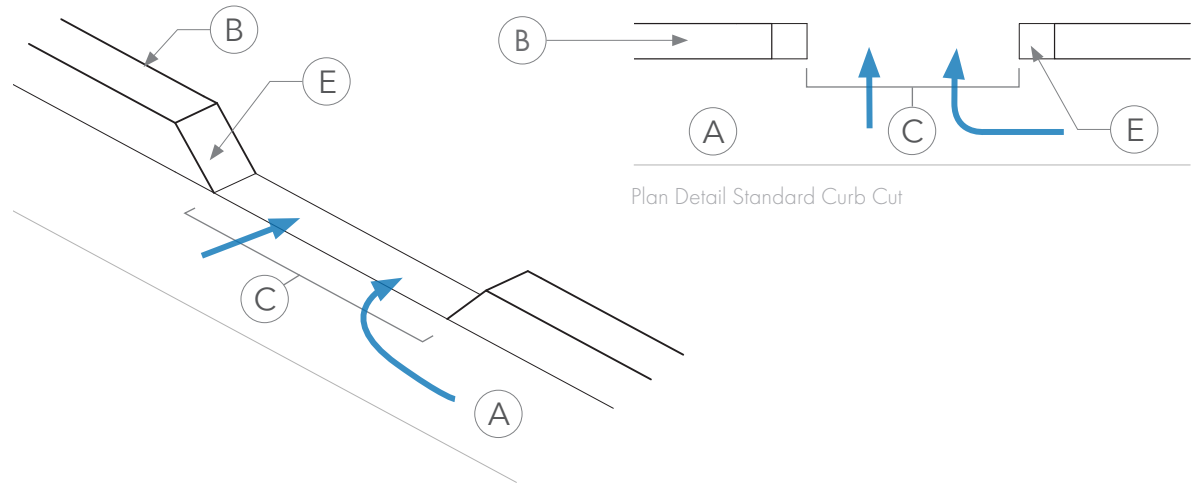

Perspective Detail Standard Curb Cut [with 45 Degree Cut Angle]

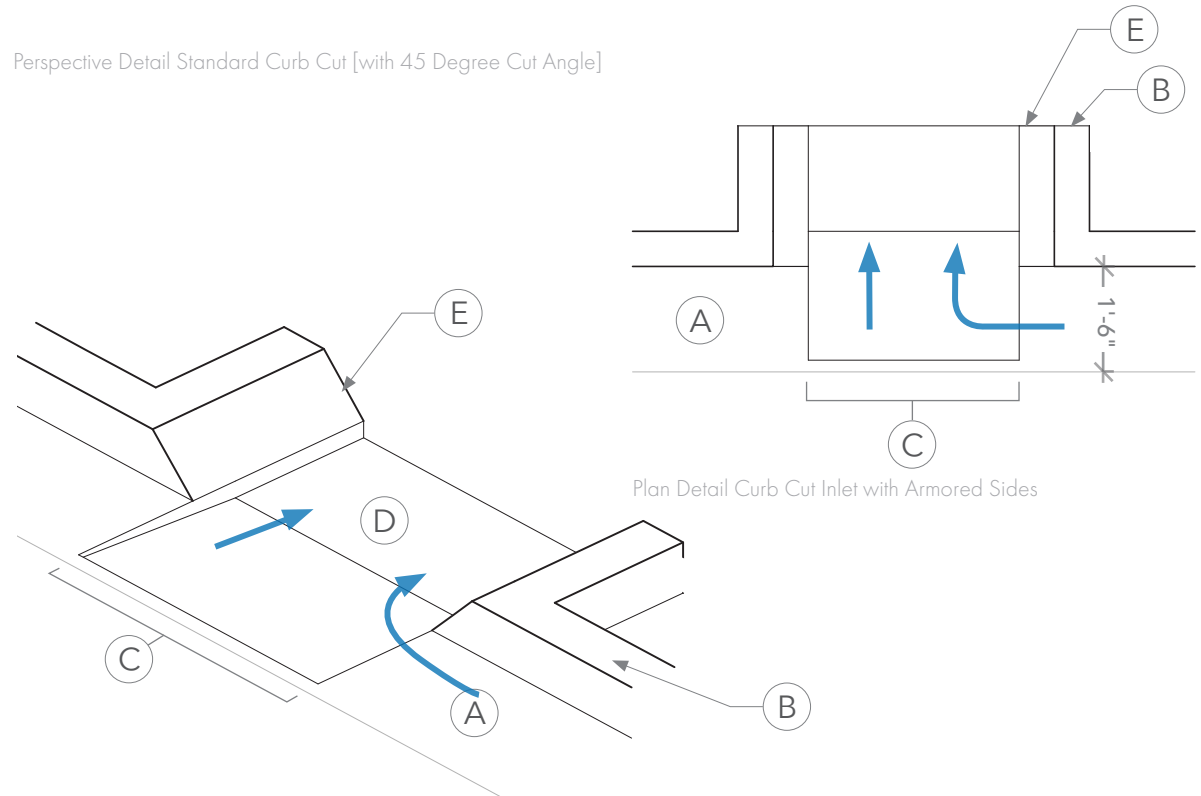

Perspective Detail Curb Cut Inlet with Armored Sides

BASIN BORDER

BASIN EDGES

The characteristics of basin borders can vary widely including edges that are vertical, terraced, or sloped, linear or sinuous, natural or engineered (Figure 16). The borders can influence volume of stormwater catchment and spillage, pedestrian and vehicle access/hazards, aesthetics, etc. Weirs, one rock dams, or other grade controls can be used within the borders to slow, pool, and infiltrate stormwater in sloped basins that would otherwise flow rapidly downhill.

The most simplistic basin borders are cobble mulched edges on a 3:1 slope. They are easy and affordable to install where broad pooling space is available, but the cobble mulch can create a good growing medium for undesired grasses, forbs, or more invasive plants (e.g. Siberian elms). Stacked angular stones or cement blocks can improve on the aesthetic appeal of GSI features in constricted spaces and cut down on weeds, but might be more costly due to labor associated with trained stone masons. Concrete curb edges used on rain gardens such as parking space retrofits or chicanes provide easily replicable borders that can create defined pooling areas more intuitively understood by traffic engineers.

Treated wood edges can be rapidly installed at a low cost, but could leach unintended chemicals into a GSI feature. When installing basin edges, it is critical that the top elevation exceeds adjacent weirs and outlet elevation (ideally by at least 4-inches) or stormwater will spill over the borders (i.e. an unintended outlet point) (Figure 17).

Figure 16. Stone or cement block stacked vertical edges (left and middle) are valuable in more constricted spaces and might help minimize recruitment by unwanted plants. Concrete borders (middle left) are easy to replicate and common in high traffic areas. Treated wood provides a linear edge (middle right) that can be quickly installed. A cobble mulch (right) on a manageable slope (e.g. 3:1) is easy to install, but the mulch will likely allow unwanted grasses/forbs to become established.





Figure 17. An example of basin edges (blue dotted line) that are lower than the intended pour over point on a weir (yellow dotted line) which leads to failure (i.e. blue arrows showing erosion from stormwater exceeding basin edge).

BASIN BORDER

DEFINITION

BOUNDARIES/EDGES THAT GUIDE, CONCENTRATE, AND DISPERSE STORMWATER FLOW AND POOLING THROUGHOUT A GSI FEATURE. THE DIMENSIONS (AREA AND DEPTH BELOW OUTLET) WITHIN THE BASIN EDGES WILL GENERALLY DEFINE THE POOLING VOLUME OF STORMWATER

CRITICAL FEATURES AND PRINCIPLES

The characteristics of basin borders can vary widely including edges that are vertical, terraced, or sloped, linear or sinuous, natural or constructed. The borders can influence volume of stormwater catchment and spillage, pedestrian and vehicle access/hazards, aesthetics, etc. Weirs, one rock dams, or other grade controls can be used within the borders to slow and pool stormwater in sloped basins that would otherwise flow rapidly downhill. Generally speaking, water depth should not exceed 12".

CONSTRUCTION NOTES:

1. Concrete curb/gutter should be installed by certified contractors. Standard dimensions are 6-inch high curbs and 18-inch wide gutters.
2. Decorative cement block should be installed according to manufacturer details.
3. Treated lumber and railroad ties can be embedded into soils as basin edges with the understanding that chemicals used to preserve wood from rot could leach into the GSI feature.
4. Soil can be tapered into 3:1 slope, seeded with grasses or wildflowers, and mulched with 2-8 inch cobble. This method is often cheaper to install than other edges and allows for more pollinator forage, but can appear less manicured.



Curb Cut Inlet.



Curb Cut Inlet with Armored Sides.



CONSTRUCTION NOTES FOR CONCRETE CURB BASIN BORDER:

1. Concrete curb/gutter should be installed by certified contractors.
2. Standard dimensions are 6-inch high curbs and 18-inch wide gutters.

KEYED NOTES FOR CONCRETE CURB BASIN BORDER:

- A. Standard concrete gutter.
- B. Shaped earth.
- C. Maximum pooling depth should generally not exceed 12".
- D. Top of Curb beyond.

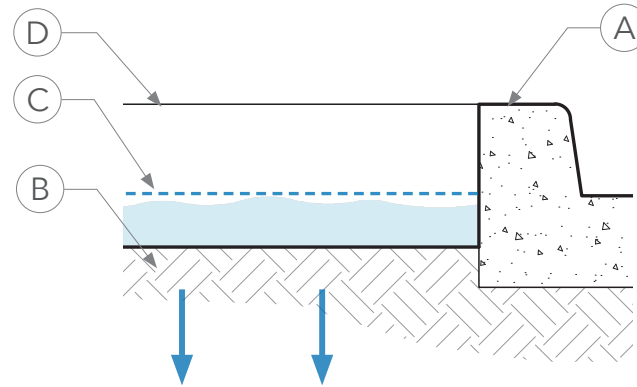

Detail Section of Concrete Curb Basin Border

CONSTRUCTION NOTES FOR CONCRETE CURB BASIN BORDER:

1. Decorative Cement Block should be installed according to manufacturers details.
2. Keep adjacent soil outside of basin or mulch 1" min. below top of wall.

KEYED NOTES FOR CONCRETE BLOCK BASIN BORDER:

- A. Standard concrete block.
- B. Shaped earth.
- C. Maximum pooling depth should generally not exceed 12".
- D. Top of wall beyond
- E. Adjacent soil or mulch

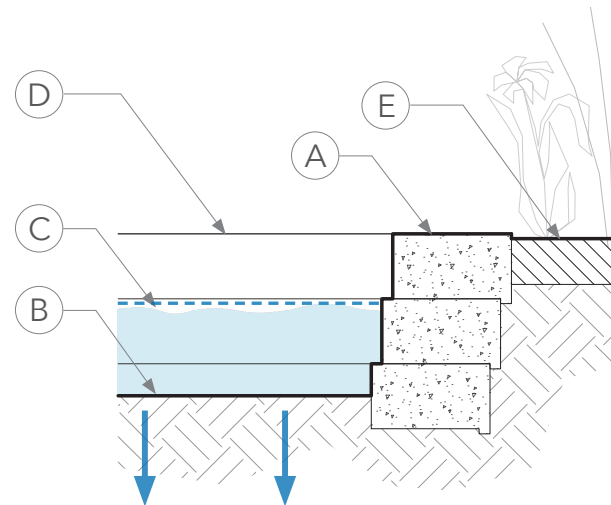

Detail Section of Concrete Block Basin Border

BASIN BORDER



Wooden Basin Border.

CONSTRUCTION NOTES FOR WOOD BASIN BORDER:

1. Treated lumber and railroad ties can be embedded into soils as basin edges with the understanding that chemicals used to preserve wood from rot could leach into the GSI feature.
2. Keep adjacent soil outside of basin or mulch 1" min. below top of wall.

KEYED NOTES FOR WOOD BASIN BORDER:

- A. Pressurized Wood.
- B. Rebar for stability.
- C. Maximum pooling depth should generally not exceed 12".
- D. Top of wall beyond.
- E. Adjacent soil or mulch.

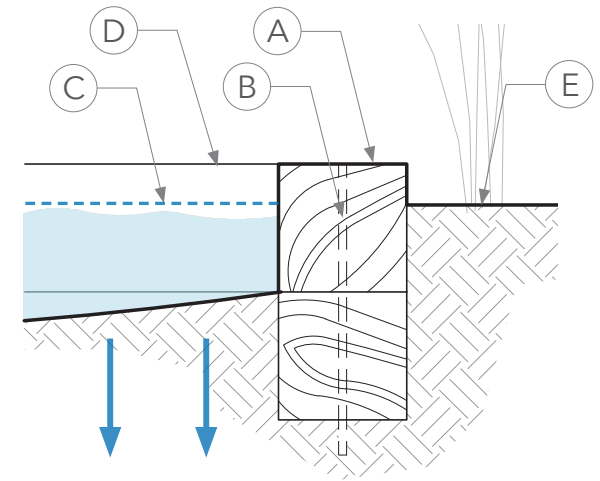

Wooden Basin Border Section

CONSTRUCTION NOTES FOR SLOPED BASIN BORDER:

1. Soil can be tapered into 3:1 slope, seeded with grasses or wildflowers, and mulched with 2-8 inch cobble. This method is often cheaper to install than other edges and allows for more pollinator forage, but can appear less manicured.

KEYED NOTES FOR SLOPED BASIN BORDER:

- A. 4-8" cobble or riprap to stabilize sides.
- B. $\leq 3:1$ slope seeded with grasses or wildflowers.
- C. Maximum pooling depth should generally not exceed 12".
- D. Top of slope beyond.

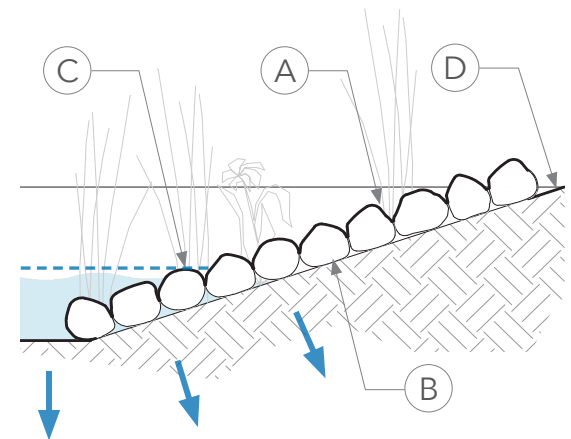

Sloped Basin Border Section



Sloped Basin Border.



CONSTRUCTION NOTES FOR ROCK BASIN BORDER:

1. Notes here

KEYED NOTES FOR ROCK BASIN BORDER:

- A. 9–12" Dry stacked rock (e.g. Limestone or Moss Rock).
- B. Soil medium to allow for infiltration
- C. Ammended Soil.
- D. Maximum pooling depth should generally not exceed 12".



Basin border constructed with Stacked Rock.

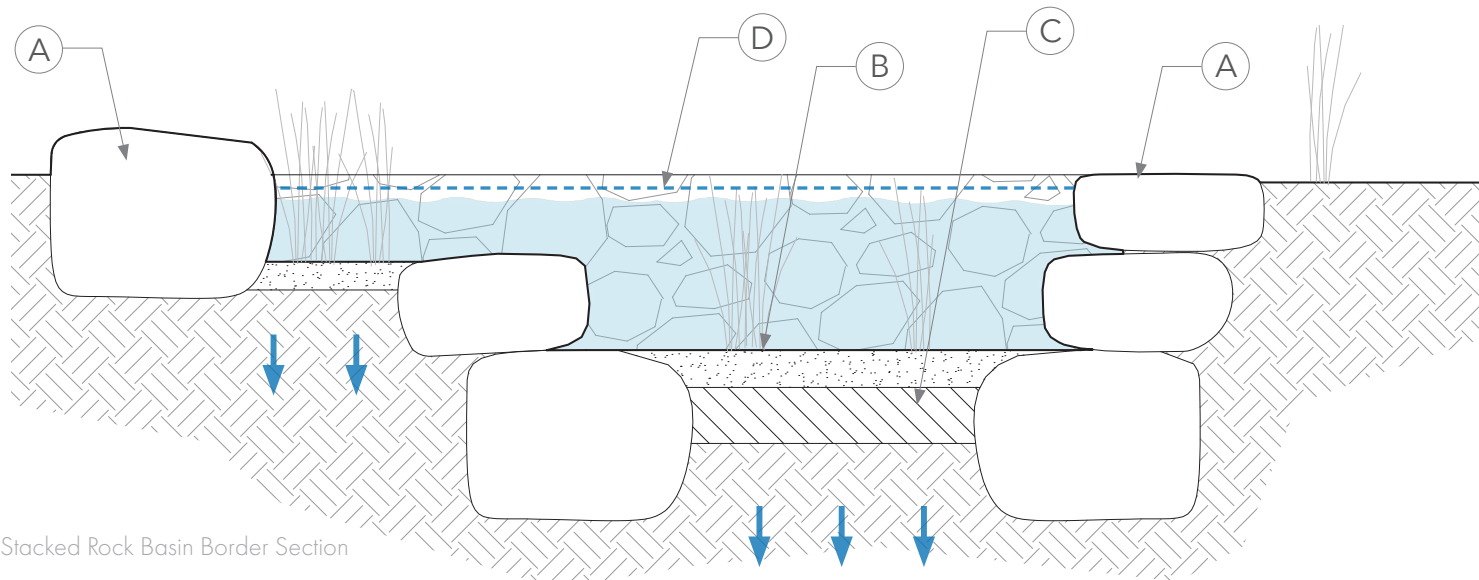

Stacked Rock Basin Border Section

URBAN ZUNI BOWL MODIFICATION

DEFINITION

A ROCK-LINED STRUCTURE INTENDED TO AESTHETICALLY LIFT, POOL, AND DISSIPATE STORMWATER ENERGY AS IT FLOWS THROUGH A GSI FEATURE.

CRITICAL FEATURES AND PRINCIPLES

A beneficial component in a GSI feature, used to lift and pool stormwater as it moves through a basin, or where increased passive irrigation is desired. This concept is an adaptation of the Zuni bowl component (page 50) that was developed in a collaborative effort by Bill Zeedyk and the people of the Zuni Pueblo. Its design differs from a standard Zuni bowl in that the elevation of the weirs and outlet are raised, decreasing the distance in elevation between the inlet and outlet to enhance the basin's pooling capabilities. This adaptation is meant to dissipate stormwater energy along gentler slopes more common to urban environments and does not have the same capacity for erosive mitigation as a standard Zuni bowl. Multiple urban Zuni bowl basins can be linked in a GSI feature (e.g. a rain garden), via weirs (page 86) or channels, to create a series of plunge-pools that can serve as an attractive dry river system that fills with water/slow and infiltrates water during storm events.

CONSTRUCTION NOTES:

1. Select a headcut for treatment, shape the headcut face for stone placement, and determine the structure dimensions (length = 3-4X the headcut height).
2. Excavate the footer and begin placing stones for the splash apron (level or only slightly protruding from the channel bed).
3. Utilize the largest rocks to begin forming the elevated lower pour over immediately upstream of the splash apron. Elevation can vary depending on desired pooling depth.
4. Create a level course of stones upstream of the pour over that fit tightly against the channel edges and headcut face.
5. Add additional courses of stone—stepping outward so as not to create a vertical edge—against the channel edges and headcut face as needed.
6. Ensure that flow will pour over the structure and into the pool by not placing stone at a height that exceeds the headcut face.
7. Cobble, sand, or dirt (in order from highest erosive energy to least) can be added to the pool to further dissipate flow energy.
8. Build a one rock dam downstream (6-8X the height of the headcut) of the structure to reinforce the splash apron. (Not shown).



Urban Zuni Bowl Modification.



Urban Zuni Bowl Modification.



KEYED NOTES:

- A. Constructed or natural channel.
- B. Inlet.
- C. Plunge pool.
- D. Boulder Size And Bowl Shape Varies Depending On Site Requirements.
- E. Pour over is at least 2" less than inlet elevation.

MAINTENANCE NOTES:

1) Inspect structure after initial storms to determine if any failure or damage occurred (e.g. stones displaced, erosion circumvented or piped through structure, etc.)

If so: Repair and reinforce with larger/more stone if necessary.

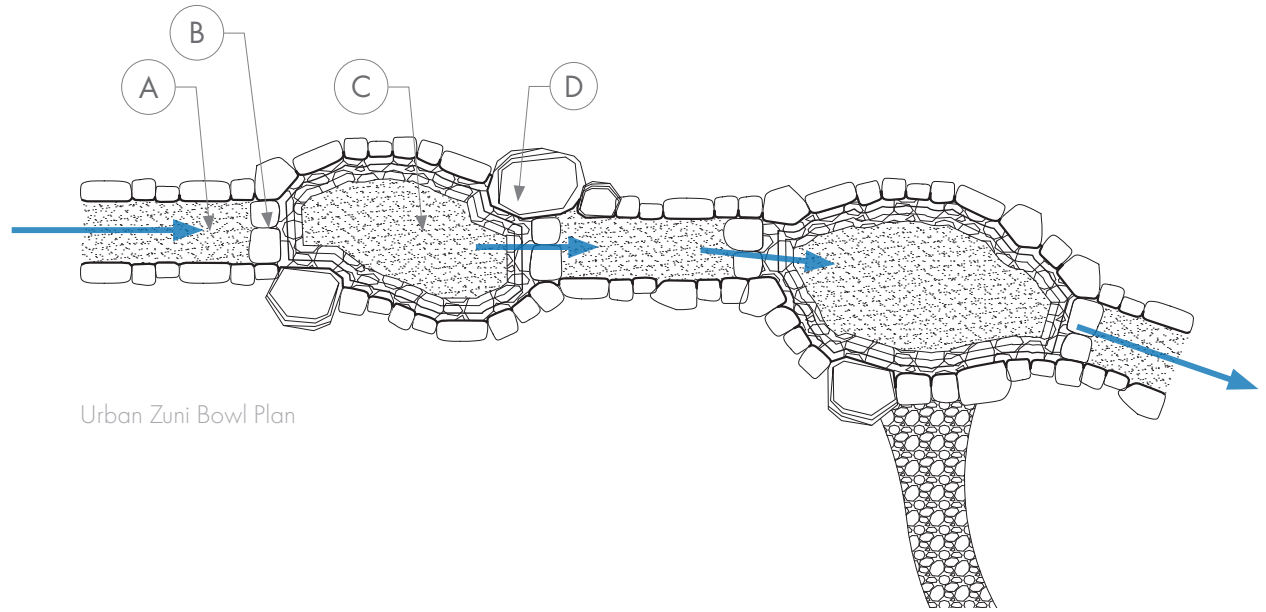

Urban Zuni Bowl Plan

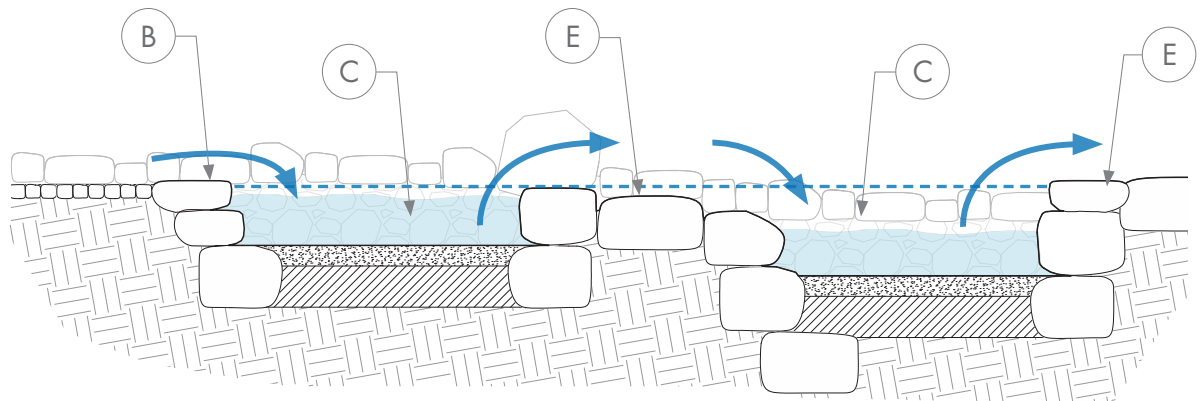

Urban Zuni Bowl Section

SEDIMENT TRAP

SEDIMENT TRAP

It cannot be overstated that sediment is likely to be the most common pollutant in stormwater runoff and will require the greatest amount of maintenance in a GSI feature. Sediment origins might include bare soil adjacent to impervious areas, basalt cinders used for road deicing during the winter, and the degradation of asphalt over time. GSI should have well-maintained sediment traps to prevent dirt and other suspended stormwater material from plugging the inlet or accumulating in the basin where pooling volume is desired for passive irrigation. Traps are intended to slow and temporarily pool stormwater as runoff enters the basin. This process reduces scour and drops out silt or larger soil textures (clays might remain suspended) before runoff continues to flow into the rest of the basin. Sediment will need to be periodically removed from the trap to ensure that material does not overflow into the basin after numerous storms. The frequency of maintenance will depend on the conditions of the areas contributing runoff and the dimensions of the trap (i.e. clean/new asphalt areas or large sediment traps will need less attention).

Sediment traps can vary in depth, but 6–15 inches below the gutter elevation at the curb inlet is a good range. The quick drop in elevation from the gutter to the trap will help draw stormwater into the GSI feature instead of it flowing past the inlet. If too shallow, the trap might rapidly fill with sediment or have insufficient pooling to effectively prevent sediment from entering the rest of the basin. If too deep, the trap might present safety concerns for pedestrians that stray too close.

It is important that sediment traps have a surface medium that will not float or be displaced by flow (e.g. gravel or cobble instead of soil or woodchips). The material of this surface medium should also be selected with the intended maintenance method in mind, ideally posing minimal interference to the process of regularly cleaning out accumulated sediment (e.g. if sediment removal will be done with a shovel, gravel would be preferred; if sediment removal will be done with suction, larger cobble would be preferred).



Sediment trap with float grass filter behind to block debris from entering the rest of the GSI feature, dry.



Water filling sediment trap before traveling through rain garden.



Ideally, the sediment trap borders should be constructed of immobile stones/blocks (e.g. limestone boulders) which holds a vertical edge, can be stepped on without tipping, and offers porosity between the stones. A concrete border also works, but lacks the benefit of having a porous edge. Bunch grasses in the trap can filter out floatable trash (e.g. plastic water bottles) but should not be planted in high densities so that sediment removal becomes more tedious. Examples of sediment traps can be found in Figure 18.



Water filling sediment trap and traveling through rain garden.



Figure 18. Examples of flow (blue arrows) into sediment traps, and approximate pooling depths before overflow into basins. **Left:** A small sediment trap approximately 6sqft and five inches deep will capture soil, trash, and other materials from the adjacent parking spaces. **Middle:** Stormwater runoff from a street is drawn into a sediment trap with a pipe overflow slightly below the elevation of the gutter. Runoff will slow, pool, and drop sediment around the pipe before stormwater overflows into the pipe and passes under the sidewalk into a bioretention basin. **Right:** A sediment trap in a parking space retrofitted as a rain garden. Bunch grasses in the trap help dissuade pedestrians from stepping into the area when turbid water obscures the depth. Note that while the trap on the right has a smaller volume than the middle trap, the area of runoff is $\sim 1/6$ the size meaning that the frequency of maintenance could be less.

SEDIMENT TRAP

DEFINITION

THE FIRST POINT OF TREATMENT IN A GSI FEATURE WHERE RUNOFF IS INTENDED TO SLOW, POOL, AND DROP DEBRIS BEING TRANSPORTED VIA STORMWATER.

CRITICAL FEATURES AND PRINCIPLES

Sediment traps might be the most underappreciated component in all of GSI design for semiarid regions due to the high levels of sediment in runoff. The size of a sediment trap will influence the functionality of the inlet, frequency of maintenance needs, and the longevity of catchment volume. Larger volume sediment traps with porous substrates (e.g. gravel) will help to rapidly dissipate stormwater discharge as it enters the basin and drops coarse textured soils, trash, and other suspended sediments.

CONSTRUCTION NOTES:

1. Identify the building materials and location for the sediment trap at the GSI feature inlet (e.g. curb cut). Angular stone or cement landscaping blocks ranging from 6-15 inches (one side) are good materials because they are easy to assemble and can withstand most erosive flow from stormwater entering the inlet.
2. Determine the dimensions of the sediment trap. The volume of a sediment trap will influence the functionality of the inlet and frequency of maintenance needs. At a bare minimum the dimensions should allow stormwater runoff to slow its velocity, temporarily pool, and drop out sediment or other suspended material (e.g. trash) before proceeding into the rest of the GSI feature. The length and width of the trap might vary depending on the area near a street right-of-way or dimensions of a median to receive a GSI feature. The depth of the trap can range from 6-15 inches. Depths greater than 9-inches should include bunch grasses or other means of alerting pedestrians to hazards when empty or filled with turbid/opaque stormwater. Bunch grasses also help filter floatable materials entering the trap.
3. Build the elevation of the pour-over point (i.e. where stormwater enters the rest of the GSI feature) lower than the inlet elevation. Two inches is usually sufficient.
4. The bottom of the trap can remain bare soil or be armored with gravel or cobble. Larger, porous substrates (e.g. gravel, cobble) will help to rapidly dissipate stormwater discharge as it enters the basin. Cobble might be necessary in sediment traps deeper than 9-inches or where stormwater velocity at the inlet is particularly erosive.



Sediment trap with float grass filter behind to block debris from entering the rest of the GSI feature.



Tiered sediment trap showing pooling and filtration stages as stormwater enters GSI feature for treatment.



KEYED NOTES:

- A. Angular stone or cement blocks.
- B. Pourover point.
- C. Trap depth ~6"–15".
- D. Inlet beyond

MAINTENANCE NOTES:

1) Check the trap at appropriate intervals (e.g. quarterly, after high-intensity storms, depending on area of runoff and trap volume, etc.) and conduct maintenance as needed (e.g. sediment removal, pour-over repairs, etc.).

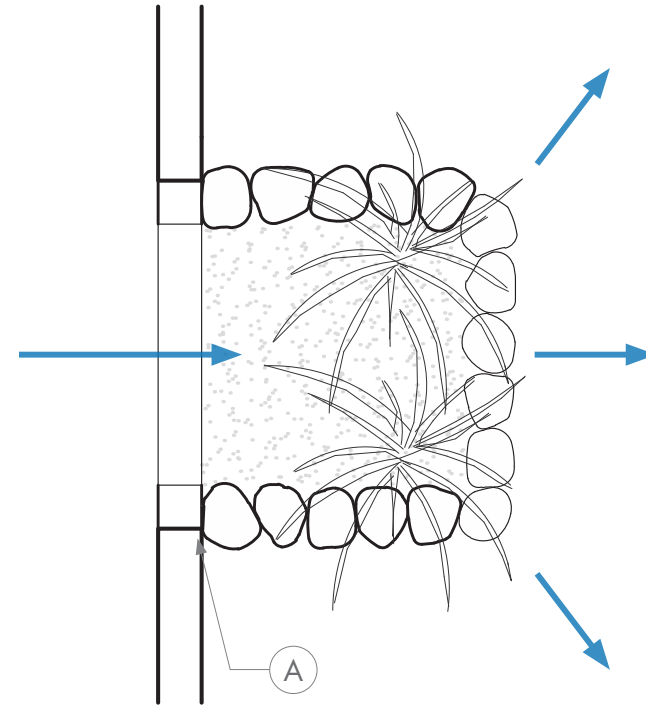

Sediment Trap Plan

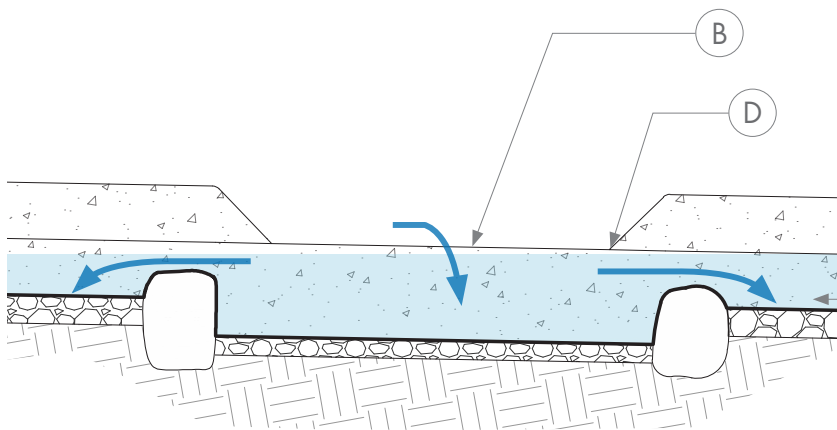

Sediment Trap Section for Raingarden Feature

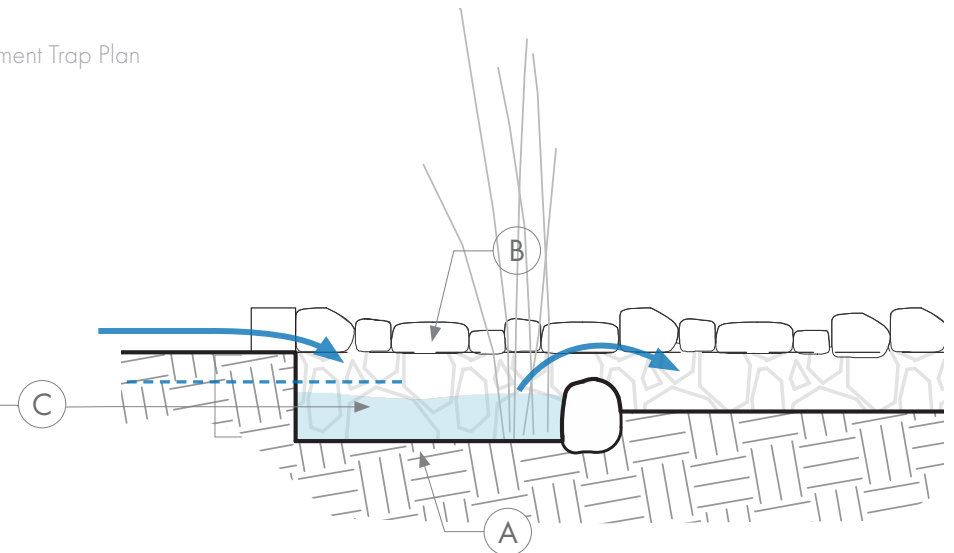

Sediment Trap Section at Parking Space Retrofit

WEIRS / OUTLETS / PONDING DEPTH

WEIRS, OUTLETS AND PONDING DEPTH

The open volume of a GSI feature intended to pool water (e.g. rain garden) is an important GSI design consideration. A basin must drain within 96 hours to comply with the New Mexico State Engineer's rules regarding impounding runoff (20). Ideally the basin should not have any standing water for more than 24 hours to reduce mosquito breeding and anaerobic soil conditions.

Pooling depth will be determined by the difference in elevation between the basin floor and stormwater outlet. Standing water depths greater than 1 foot should generally be avoided, especially where pedestrians might attempt to cross features or where infiltration rates are slow. Weirs can be added in basins that slope in order to lift/pool and prolong soil moisture between the inlet and outlet locations (Figure 19).

Outlet dimensions should always be capable of discharging stormwater as fast or faster than the GSI feature's inlet. The inability of runoff to exit a GSI feature could cause stormwater to reach unsafe depths or overflow at unintentional locations along the basin edges. In some cases the overflow of a basin can be mitigated by ensuring that basin edges exceed the outlet and inlet elevation at all points. This will prevent stormwater from continuing to enter the basin if the outlet is plugged, but might still lead to deeper pooling conditions than desired. To estimate the pooling volume of a GSI feature, see the calculations on the following page (Figure 20).



Figure 19. An example of a weir (blue arrows) in a rain garden which forces stormwater to pool a certain depth before it can overflow to the next basin. Weirs can concentrate stormwater near trees to enhance irrigation, above woodchip sponges to improve filtration, or simply to slow stormwater velocity as it passes through a GSI feature.

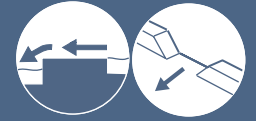

GREEN STORMWATER INFRASTRUCTURE PRACTICE EXAMPLE

Estimating the catchment volume of rain gardens, bio-retention basins, or other pooling GSI features requires measurements of pooling depth and the extent of pooling area. Pooling depth is the difference in elevation from the basin bottom to the top of the outlet. Multiplying the pooling depth (ft) × the pooling area (ft²) will give a volume in cubic feet (ft³) which can be multiplied by 7.48 gallons/ft³ to determine gallons. For example, a rain garden with a pooling depth of 9 inches over 200 ft² would capture over 1,100 gallons.

$$\frac{0.75 \text{ ft}}{\text{ft}^3} \times \frac{200 \text{ ft}^2}{\text{ft}^2} \times \frac{7.48 \text{ gallons}}{\text{ft}^3} = 1,122 \text{ gallons}$$

If the basin bottom is sloped or if a series of stepped pools are used in sequence, then more precise measurements of depth that account for the average depth need to be calculated (see diagram below).

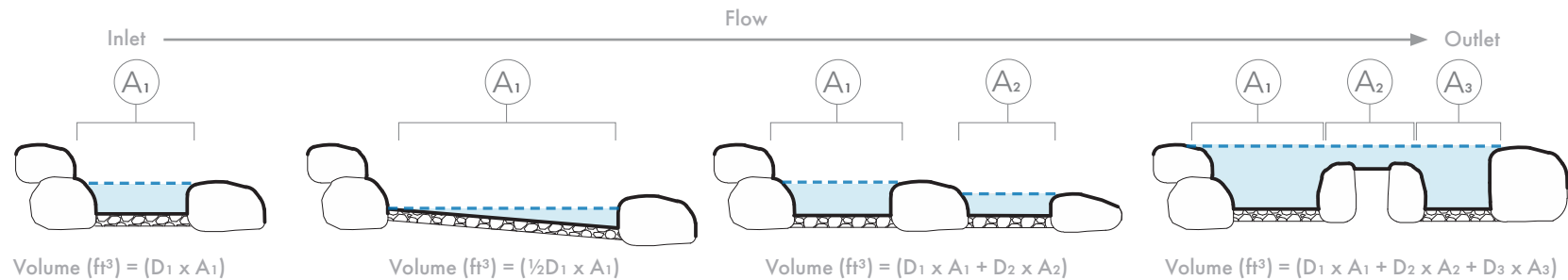

To determine the depth of a storm that a basin can capture, divide the basin volume (gallons) by the volume (gallons) of stormwater from the known area of runoff during a 1-inch storm (see calculation for runoff earlier in document). For example, a basin that captures 1,122 gallons from a 4,000 ft² asphalt area that generates 1,995 gallons in a 1-inch storm would effectively capture a 0.56-inch storm. Note that estimates of pre-development soil hydrology for Santa Fe County indicate that runoff likely occurred during storms <0.68-inches (21). Thus, capturing a storm around 0.5-inches could be akin to infiltrating runoff prior to soil disturbance.

$$\frac{1,122 \text{ gallons (basin volume)}}{1,995 \text{ gallons (volume per inch storm)}} = 0.56 \text{ in storm captured}$$

Figure 20. A practice example for calculating catchment volume in rain gardens, bio-retention basin, and/or other pooling GSI features.

WEIRS

DEFINITION

WEIRS ARE INTENDED TO INCREASE POOLING AND REDUCE EROSION WITHIN GSI FEATURE (E.G. RAIN GARDEN) BY SLOWING AND LIFTING STORMWATER.

CRITICAL FEATURES AND PRINCIPLES

Weirs can be easily constructed with stone, but other materials can be used including concrete, cement landscaping blocks, logs, or metal. Cobble check dams and gabions are sometimes used as weirs, but tend to be leaky and might not pool stormwater as effectively.

COMMON IMPLEMENTATION MISTAKES:

If weir height exceeds height of basin edges, it could lead to breaching (i.e. a high storm water event could cause flooding along basin edges as the water exceeds their volumetric capacity and cannot easily pass through the weir, instead spilling over the side of the basin, creating a damming effect).

CONSTRUCTION NOTES:

1. Identify locations within a basin where a weir could improve pooling, reduce scour from steeper slopes, etc.
2. Determine the appropriate elevation of the weir, ensuring that maximum elevation does not exceed berm edges at adjacent or upslope locations.
3. Choose an appropriate weir material that considers impermeability vs minor leakiness, ability to withstand erosion, cost, etc.
4. Build the weir across the entire width of the basin (i.e. from basin edge to basin edge), but below the basin edges. If the weir elevation exceeds the basin edges adjacent to or upslope of the weir, then flooding or breaching could occur.
5. Consider maintaining a slightly concave shape in the center of the weir (concrete weirs often have a notch) to ensure that flow is maintained through the middle of the structure instead of potentially scouring the basin edges; particularly if edges are bare soil.
6. Install a splashpad (e.g. gravel, cobble, small embedded boulders, etc.) to mitigate scour at pour-over point, particularly on higher weirs or in GSI features with steeper slopes and rapid flow.
7. Periodically inspect (and mitigate) if erosion or piping is occurring on the edges or below the structure.



Stone weir construction.



Stone weir with flowing water.

**KEYED NOTES:**

- A. Weir elevation < Berm Edges (adjacent or upstream).
- B. Pooling depth created by weir.
- C. Splashpad.
- D. Flow from inlet.
- E. Flow to outlet.

MAINTENANCE NOTES:

- 1) Periodically inspect (and mitigate) if erosion or piping is occurring on the edges or below the weir.

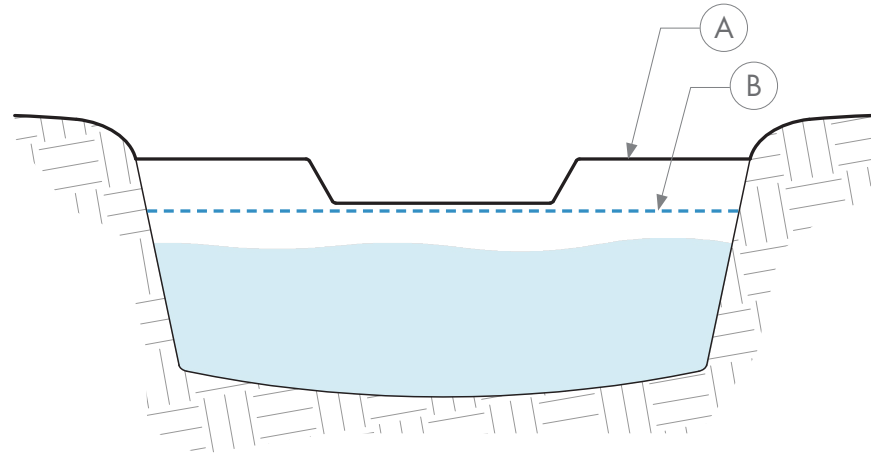

Concrete Weir Cross Section

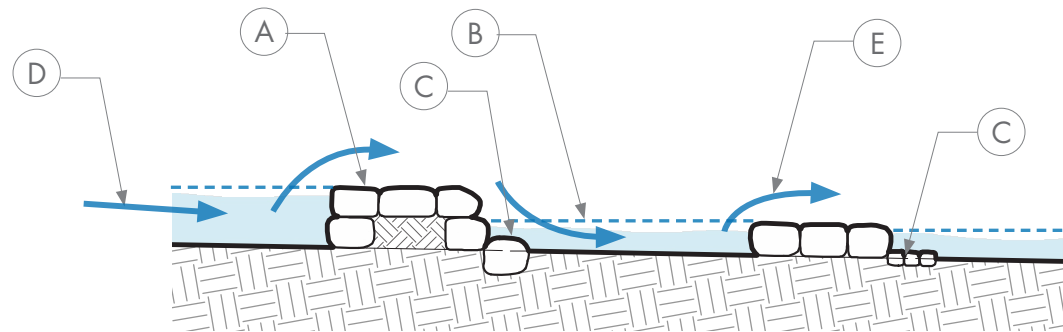

Stone Weir Section

OUTLETS

DEFINITION

A STORMWATER POINT OF EXIT FROM A GREEN STORMWATER INFRASTRUCTURE FEATURE.

CRITICAL FEATURES AND PRINCIPLES

The stormwater discharge rate at outlet must be greater than or equal to the rate at an inlet or the basin has potential to flood. Outlet elevation dictates maximum pooling depth (assuming that outlet is not plugged--> worth considering where stormwater will flow if the outlet is plugged...will water pool deeper; will stormwater backflow out of inlet; is the lowest part of the berm edges in danger of breaching, is the lowest part of the berm edges armored against erosion etc.)

COMMON IMPLIMENTATION MISTAKES

Avoid installing a curb cut outlet at the highest point in a median (i.e. this would serve as an inlet) or at a point along a curb that stormwater does not flow towards. Outlets with insufficient width commonly plug with sediment/debris or fail to maximize inflow of stormwater.

CONSTRUCTION NOTES:

Curb Cut Outlet

1. Secure a curb cut permit if required by local codes/ordinances.
2. Use a concrete saw with a blade diameter of at least 14".
3. Cut the two ends of the inlet width ensuring that the blade reaches down to the gutter elevation.
4. Make similar cuts every 2"-4" between the two initial cuts.
5. Use a mallet or large hammer to break and remove the 2"-4" pieces.
6. Grind down any remaining pieces at the gutter elevation to ensure that stormwater easily exits the outlet.
7. If the concrete saw blade can be tilted and is long enough, cut 45° angles at the curb cut inlet edges to reduce the vertical edge.



Curb cut can function as both the inlet and outlet when necessary.



Curb cut outlet at lowest point.

**KEYED NOTES:**

- A. Standard 18" gutter width.
- B. Standard 6" high X 6" wide curb.
- C. Outlet width can vary depending on flow of stormwater and area of runoff.
- D. OPTIONAL: Concrete apron can be included during construction of new inlet to minimize scour at back of curb.
- E. 45° angle cut.

MAINTENANCE NOTES:

- 1). Periodically assess outlet condition for impediments to flow, erosion, or other hazards. Correct issues if present.

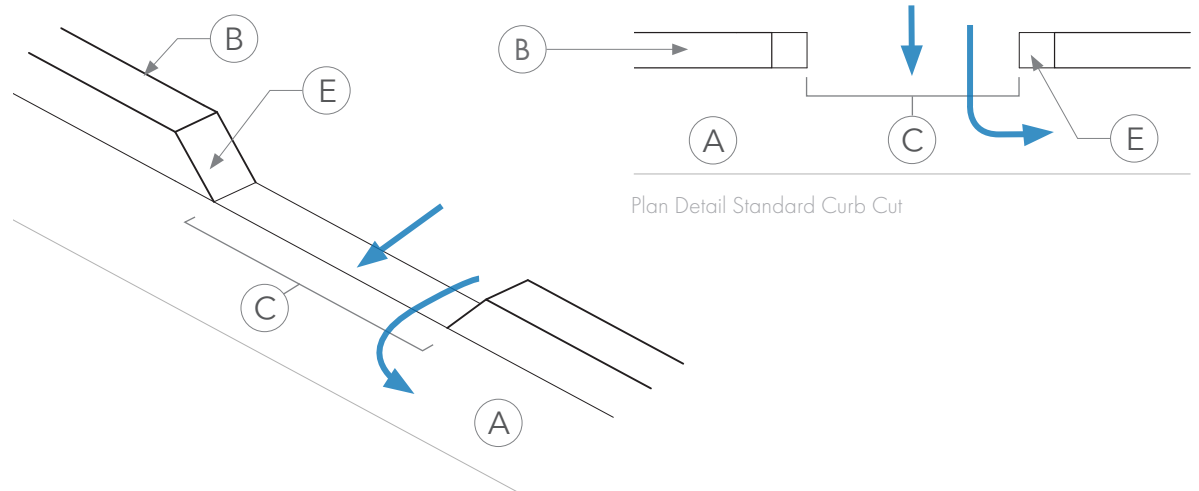

Plan Detail Standard Curb Cut

Perspective Detail Standard Curb Cut [with 45 Degree Cut Angle]

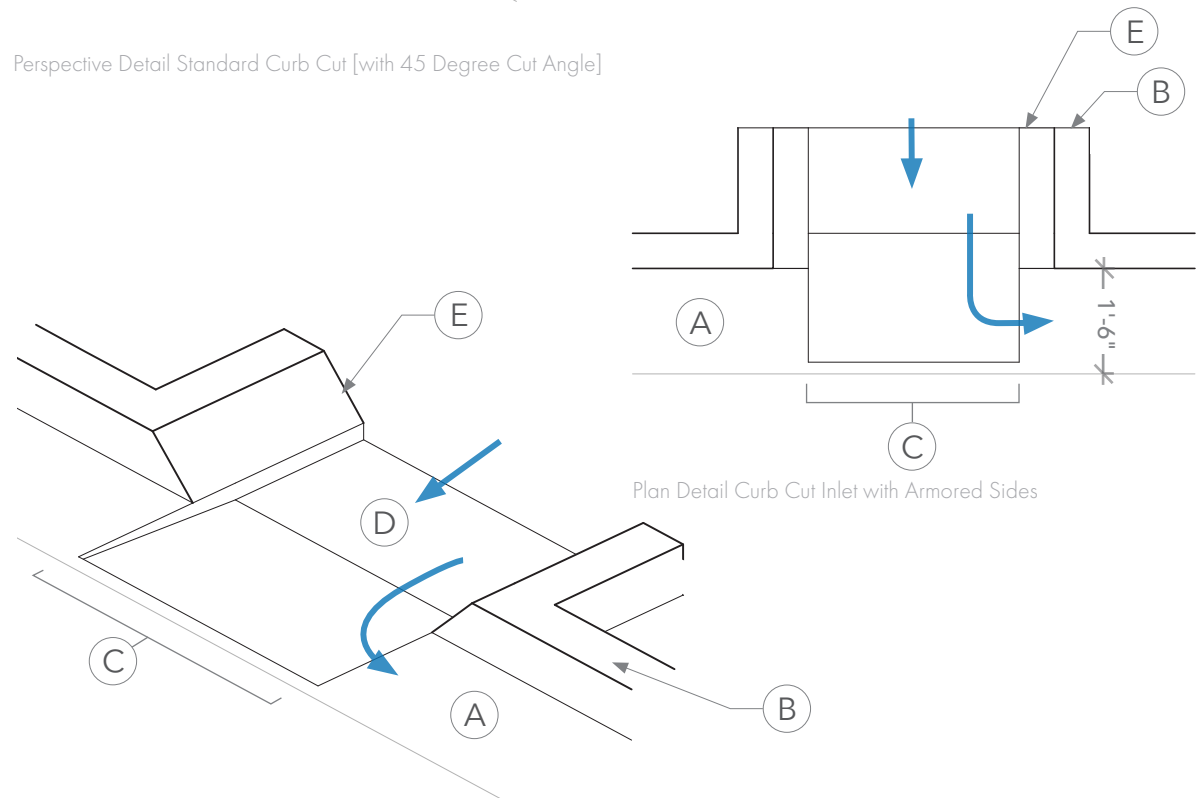

Plan Detail Curb Cut Inlet with Armored Sides

Perspective Detail Curb Cut Inlet with Armored Sides

SOILS / TEXTURE & STRUCTURE / ROOTING VOLUME / HYDROLOGY

SOIL/TEXTURE & STRUCTURE

Soil variables will significantly affect the efficacy of GSI. Soil is composed of four elements including geologic parent material (e.g. weathered granite, limestone, etc.), organic matter (e.g. decomposed leaves, manure, micro-organisms, etc.), air, and water. The degree to which parent material has weathered over time will influence its texture (e.g. clay, silt, sand, gravel, etc.). Texture will affect infiltration rates (i.e. how quickly water enters the soil surface) and water holding capacity (i.e. the volume of water soil will maintain between storms and the ease with which it is extracted by plant roots). For example, soil dominated by fine clays might have slow infiltration rates compared to coarse sands, but will retain water better for plants between storms.

Maps with general information regarding soil profile textures, estimated infiltration rates, and water holding capacity can be generated using the NRCS WebSoil Survey (11), but conducting a soil texture feel test and infiltration rate test are recommended at potential GSI sites.

Higher concentrations of decomposed organic matter will improve soil structure; often described as healthy topsoil. Good soil structure will positively influence infiltration and water holding capacity. Nutrient availability for plants from compost and wood mulches are other soil factors related to organic matter. Woodchip mulch will reduce evaporation and slowly release nutrients through decomposition processes, but should not be used in GSI features with stormwater current or mulch could float away. Compost integrated into more porous textures can

improve water holding capacity between storm events and be capped with a cobble mulch if erosion within the GSI feature is a concern.

GSI research has also found that the inclusion of certain types and depths of organic mulches and textures can filter and degrade common stormwater pollutants including heavy metals, petroleum products, sediment, etc. GSI features that have specifically amended, mixed, and deeper soil profiles are typically referred to as bio-retention basins (Figure 21). In some cases pollutant removal from bio-retention basins can exceed 90 percent of inputs (12), however, excess organic matter, particularly compost, might also increase nutrient outflows (e.g. phosphates and nitrates) above desired levels. While this could be less of a problem in more nutrient deprived and xeric soils of Santa Fe

County compared to wetter regions of the country, considerations of high nutrient levels near water resources (e.g. rivers, ponds, shallow groundwater, etc.) should be made to avoid eutrophication or other water quality concerns.

ROOTING VOLUME

Perhaps the most underappreciated soil factor in GSI features is rooting volume for healthy urban trees. Conventional methods of planting urban trees often include drip irrigation near the root collar and heavily compacted impervious surroundings. Minimal soil volume and a narrow extent of soil moisture around the roots will inhibit trees from maximizing health, size, and longevity. Landscape architects, urban foresters, and others have attempted to correlate healthy, mature tree dimensions with soil volumes (13).





Older estimates suggested that healthy, moderate growth required approximately 1.25ft³ of soil per 1ft² of canopy cover, but more contemporary recommendations have increased the ratio to 2ft³ per 1ft² (Figure 22). Most tree roots will be located in shallow portions of a soil profile and therefore estimates of soil volume should not use calculations of depth greater than three feet. Note that it is imperative to conduct a subgrade utility check prior to digging GSI basins, particularly if pooling depth, soil amendments, rooting volume improvements, etc. exceed 12-inches or are excavated with machines. A few consideration with respect to soil in GSI design can be found in Figure 23.

Figure 21. (see below) An example of amending soils by integrating compost and improving porosity through decompaction (below). The parking space is approximately 150sqft and soil is loosened 30-inches down, helping to create roughly 375 cubic feet (i.e. 150sqft X 2.5ft = 375 cubic feet) of improved rooting volume (middle) to support a healthy tree.



Figure 22. Bio-retention basins (opposite page) often include deep layers or mixes of woodchips, compost, sand, and gravel to infiltrate and filter large volumes of stormwater runoff. The image includes 12-inches of woodchips that were subsequently capped with a mixture of compost and sand to rapidly infiltrate and filter runoff from over 1-acre of neighborhood streets. The compost/sand mix prevented the woodchips from floating in roughly 18-inches of potential pooling depth.

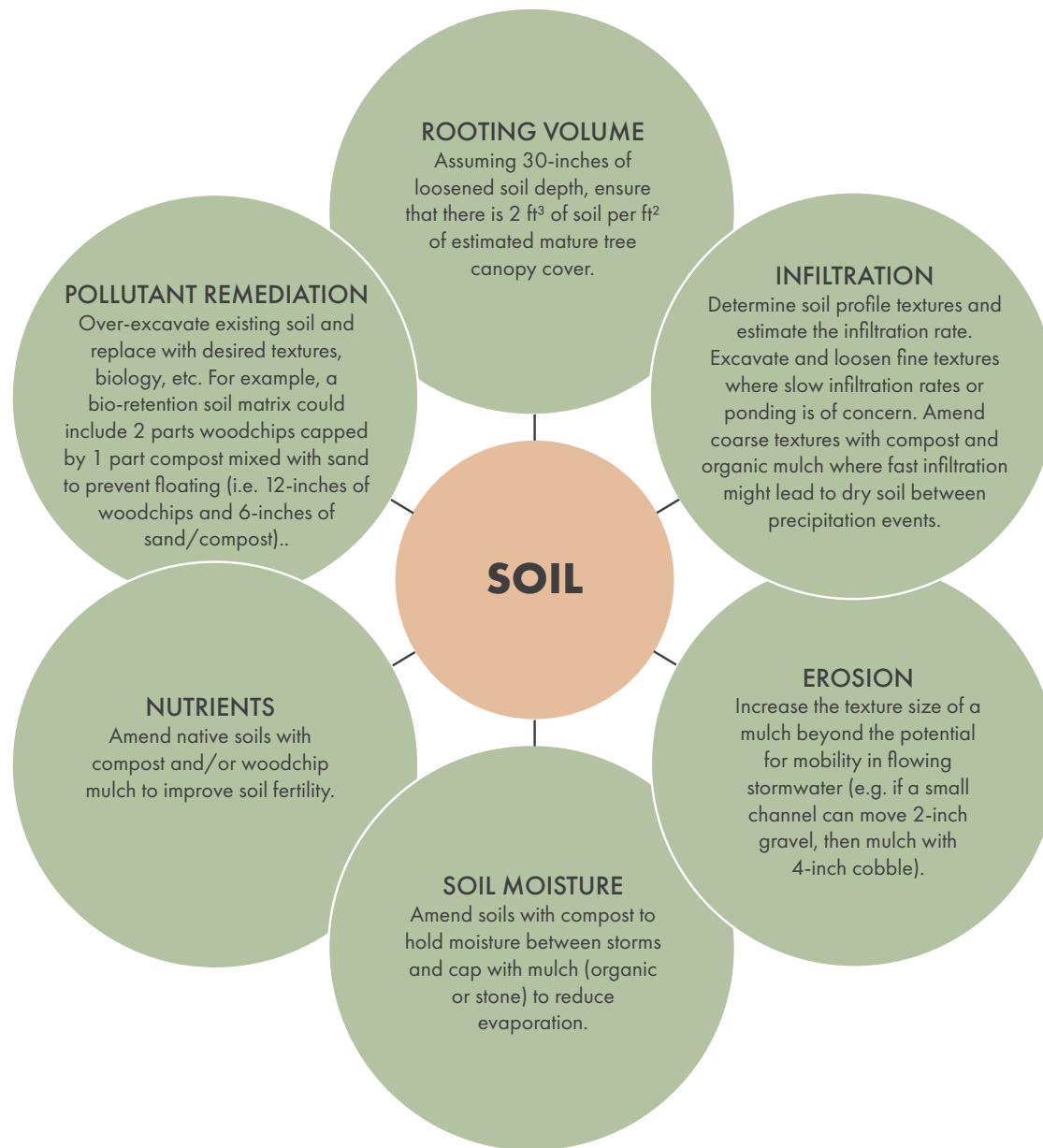

Figure 23. (see above) The functionality of GSI design relies on good soil assessment and amendments. A few considerations related to soil can be found in the graphic above.

SOILS/ TEXTURE & STRUCTURE/ROOTING VOLUME /HYDROLOGY

DEFINITION

A COMBINATION OF FOUR INGREDIENTS (ORGANIC MATTER, PARENT MATERIAL/ROCK , AIR, AND WATER) THAT ARE NATURALLY ORDERED INTO HORIZONS OVER TIME AT UNDISTURBED SITES, BUT CAN REQUIRE AMENDING TO IMPROVE NUTRIENTS, INFILTRATION, AND OTHER FACTORS AT DISTURBED OR URBAN LOCATIONS.

CRITICAL FEATURES AND PRINCIPLES

Soil texture and structure will influence the amount of air and water available to plant roots. Texture is a measure of particle size. Coarse textures (e.g. sand) have large pore spaces while fine textures (e.g. clay) have small pore spaces. Large pore spaces infiltrate and drain quickly, resulting in rapid recharge, but also potentially drier soil moisture conditions for plant roots between storms. Fine texture soil has slow rates of drainage which can sometimes result in excessively wet conditions after storms. Loam soils have a good proportion of soil textures that allows for appropriate drainage and water holding capacity for plants. Texture will also influence erodibility.

Soil can be amended with organic matter (e.g. compost, woodchips) to improve structure which in turn results in better porosity, water holding capacity, nutrient availability, etc.

Woodchips: highly porous (>50% air space by volume) organic material that can be used as:

1. a mulch to reduce evaporation and cool subsoils,
2. a porous substrate to increase permeability and filtration in bio-retention basins,
3. long term soil nutrient source through decomposition;

Compost: decomposed organic material that can significantly increase water holding capacity of soils, readily provide nutrients for plants, improve soil structure to increase infiltration; Gravel/cobble mulch helps armor the soil surface against erosion, offers large pore space for substrates aimed at rapid infiltration (e.g. pumice wicks or below permeable pavement);

Sand/Silt/Clay textures are size classes referred to in the soil triangle and will significantly affect infiltration during storms and water holding capacity between storms depending on the proportion of each texture size.

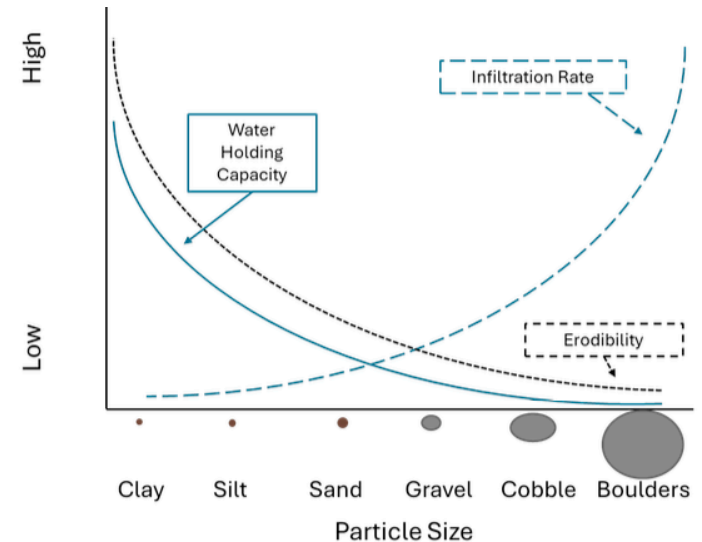
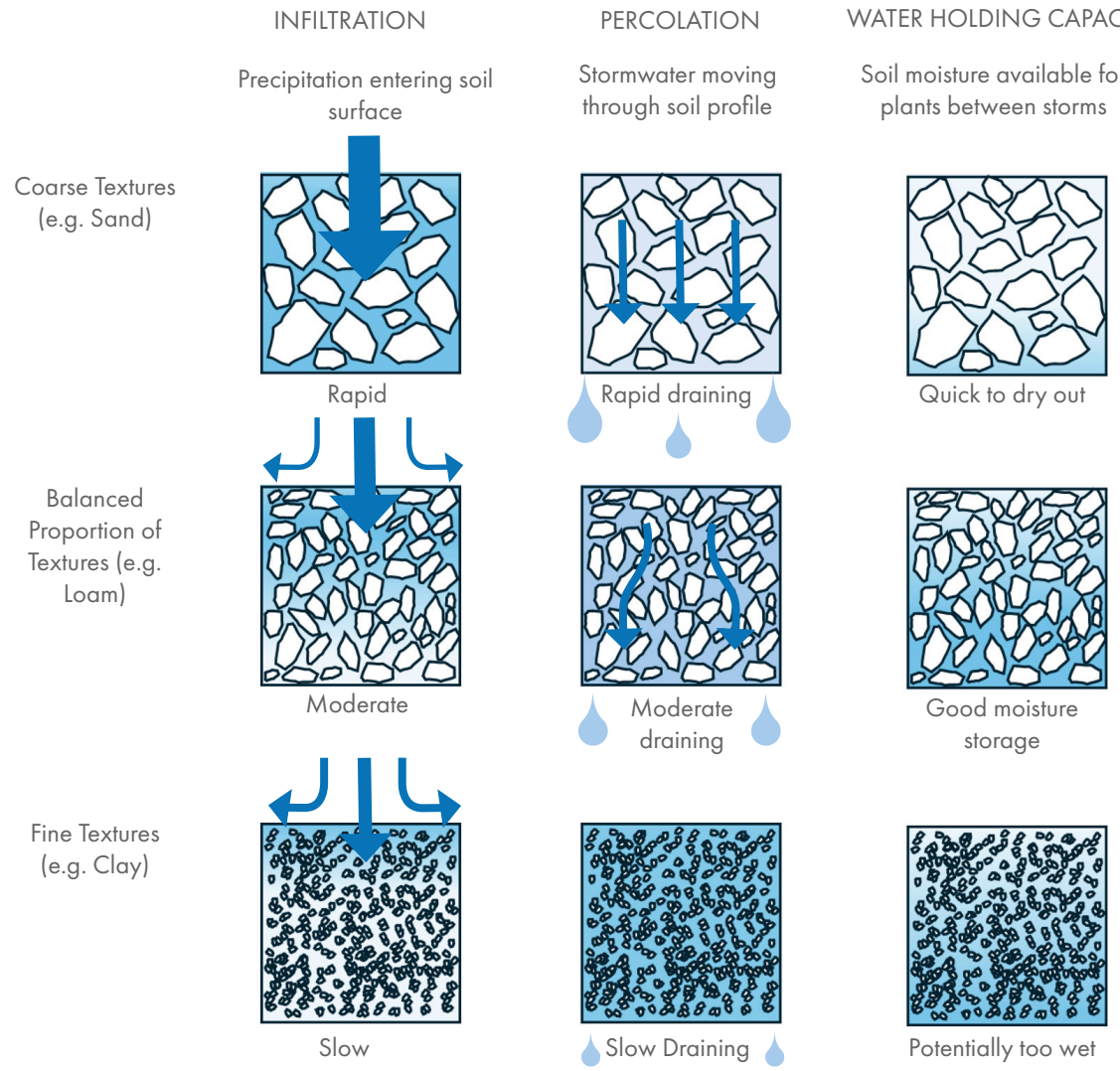

Chart illustrating the relationship between particle size, water holding capacity, and infiltrate rate.



Exposed soil with roots.



RECOMMENDED SOIL AMENDMENT CONSTRUCTION NOTES:

- 1. Integrate $\geq 3"$ of compost to improve water holding capacity and nutrients.
 - 2. Add appropriate mulch to reduce evaporation (e.g. woodchips and/or prevent erosion (e.g. cobble).
-
- 1. Cap or integrate $\geq 1"$ of compost to improve water holding capacity and nutrients.
 - 2. Add appropriate mulch to reduce evaporation (e.g. woodchips) and/or prevent erosion (e.g. cobble).
-
- 1. Cap or integrate $\geq 1"$ of compost to improve structure, porosity, and nutrients.
 - 2. Add appropriate mulch to reduce evaporation (e.g. woodchips) and/or prevent erosion (e.g. cobble).
 - 3. DO NOT mix in sand to improve porosity (results in cementing).

Graph depicting relationship between soil particle size and infiltration rate.

SOILS / TEXTURE & STRUCTURE / ROOTING VOLUME / HYDROLOGY

DEFINITION

ROOTING VOLUME INFLUENCES THE AVAILABILITY OF NUTRIENTS, SOIL MOISTURE ACCESS, & OTHER QUALITIES NEEDED FOR HEALTHY, LONG LIVED TREES.

CRITICAL FEATURES AND PRINCIPLES

Assume ≤ 3 ft depth when calculating soil volume.
Loosen compacted soils to improve in-field root expansion.

COMMON IMPLEMENTATION MISTAKES:

Failure to conduct utility check prior to excavation.

SOIL ROOTING VOLUME CONSTRUCTION NOTES:

1. Identify area for soil excavation.
2. Locate utilities, assess soil, and calculate soil volume (d x w x h) to aid in tree species selection, conditions for compaction, nutrients, infiltration rates, etc.
3. Excavate soil to depth for appropriate pooling volumes, amendment replacement (e.g. compost and mulch depth), etc. For example, remove 12" of soil if 6" of pooling volume, 2" of compost, and 4" cobble is to be used. If soil is heavily compacted (e.g. parking space retrofit), then loosen underlying soil 2-3' deep with compost amendments.
4. Amend soil to achieve appropriate infiltration, porosity, water holding capacity, nutrients, erosion mitigation, etc.
5. Add plants, mycelium inoculated logs, and other materials as desired.

MAINTENANCE NOTES:

- 1) Periodically inspect and mitigate issues such as erosion, invasive weeds, etc.

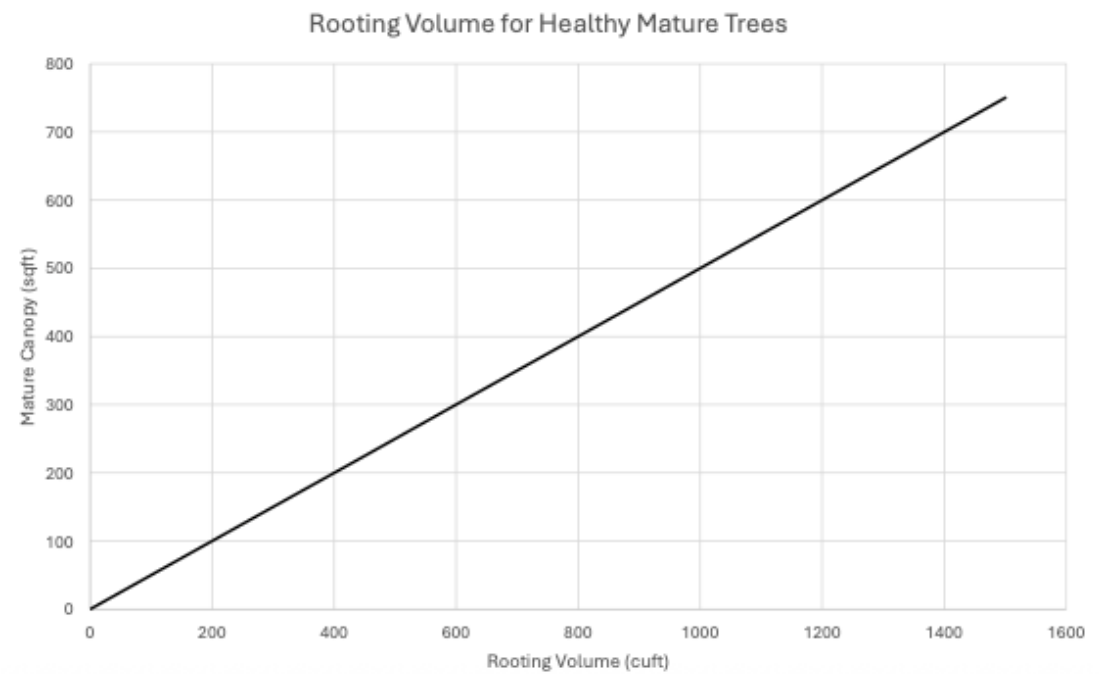

Soil hydrology chart



Soil Rooting Volume



Expected Healthy Mature Tree Dimensions Based on Soil Volumes

Graph depicting relationship between expected mature canopy of tree and suggested rooting volume.



MYCOREMEDIATION

In-vitro studies have shown that saprophytic white rot fungi, due to their unique mode of digestion, growth, and formation of mycelial networks, are highly capable of degrading PAHs and other toxic aromatic compounds found in stormwater (1,2). The biological mechanisms exhibited by fungi are highly complex and, in many cases, novel. One of these mechanisms includes a mode of nutritional uptake — fungi are unique in that they are absorptive heterotrophic organisms. This highly unique form of digestion is what allows fungi to dominate terrestrial ecosystems on Earth and act as a bioremediation species. Fungi grow through soil mediums via highly branched mycelial networks, and due to the extremely small diameter of hyphae (one cell wall thick), fungi have the highest surface-area-to-volume ratio than any other multicellular organism, making them apt for absorption (3).

During the decomposition process, complex biomolecules, such as lignin, are resistant to degradation and must be broken down into smaller components. Saprophytic fungi specifically, can breakdown and digest these complex carbon structures, including lignin (4,5). Lignin is a highly branched phenylpropanoid polymer that is highly resistant to degradation, and is similar in molecular structure to hydrocarbons found in urban environments. In fact, degradation of lignin is restricted to saprophytic fungi, especially in the phylum Basidiomycota (1,2,4,5). These fungal species are referred to as ligninolytic fungi. Lignin has a high molecular weight and is an insoluble plant polymer composed mainly of methoxylated

derivatives of benzene (phenylpropanoid alcohols), also called monolignols (4,5).

Lignin is extremely tolerant to decomposition; it has predominant ether linkages, carbon-carbon bonds, and the presence of few hydroxyl groups that take part in cross linkage to other polysaccharides and proteins and, most importantly, the predominance of benzene rings (1,4,5). Other microbes in the soil matrix that attempt to degrade lignin end up producing anti-microbial disinfectants as benzene rings, especially phenols that are toxic (6). This is one of the key functions of lignin in the matrix of plant cell walls. Enzymatic degradation of polysaccharides, proteins, and lipids is done by hydrolases, cleaving polymers of the subunits, however, this cleavage does not work with lignin. The cleavage of ether and carbon-carbon bonds that join subunits of lignin polymers is an oxidative process and is broken down by specialized enzymes produced specifically by Basidiomycota (5,6).

This group of white rot fungi (WRF) utilize a select group of enzymes that cleave ether bonds and benzene rings (6). These enzymes include lignin peroxidase, manganese peroxidase, and laccase (a copper-containing protein). Lignin and manganese peroxidase utilize hydrogen peroxide to catalyze oxidation of lignin (6,7). Laccase demethylates side chains of lignin components, exposing oxygen on phenolic rings. These enzymes are unique to saprophytic fungus, and their ability to degrade a polyphenolic compound such as lignin gives insight into how these fungal species can also degrade other similarly structured

compounds such as PAHs and other aromatic compounds like benzene/toluene/xylene (6,7).

Various species of the white rot fungus *Pleurotus* (common name is Oyster Mushroom) has been shown to be a model organism for the removal of various hydrocarbons. Mineralization of various hydrocarbons (phenanthrene, pyrene, anthracene, benzopyrene, fluorene and fluoranthene) has been successful by using C14 labeled analysis methods (3, 8, 9, 10). *Pleurotus ostreatus* was shown to metabolize three major PAHs, including pyrene, anthracene, and phenanthrene adsorbed to soil particles by 50%, 68% and 63% respectively after 21 days (3, 8, 9, 11). *Pleurotus ostreatus* was also shown to oxidize benz(a)pyrene, although it was not mineralized completely (9,11). PAHs in aqueous solutions have a very low solubility due to their chemically non-polar nature. This limits bioavailability of PAH molecules, making them difficult for microbial attack.

Bacteria have been known to produce emulsifying agents during degradation of molecules similar to PAHs in the degradation process to promote the solubility of the substrate (9). Interestingly, *Pleurotus ostreatus* specifically has been found to produce an emulsifying agent during degradation of PAHs (9). Primary production of an emulsifying agent by *Pleurotus ostreatus*, in combination with secretion of laccase, was shown to aid in not only the solubility of PAHs (mainly three and four ring PAHs), but also increasing catalytic activity of other ligninolytic enzymes during the degradation process (9,10).

This new discovery of a unique aspect of *Pleurotus*

ostreatus enzymatic productivity makes this species a novel organism for further study. Furthermore, studies completed using *Pleurotus ostreatus* in co-culture of other soil microbes in PAH degradation showed that despite antagonistic interaction, the specialized capabilities of *Pleurotus ostreatus* were preserved, and the species decomposition differences appeared to complement each other (9,10).

Perhaps the most interesting aspect of white rot fungal decomposition is in their biochemical pathways, which take hydrocarbon-based structures and convert them to biomolecules. These biomolecules (carbohydrates, lipids, nucleic acids and amino acids) can be directly assimilated by the fungi, or the surrounding environment when the fungi are consumed or decay (13). WRF exhibit a unique biochemical pathway for the breakdown of lignin and its constitution of aromatic hydrocarbons.

The beta-ketoadipate pathway (b-KAP) is considered one of the major microbial pathways for the dissimilation of aromatic and hydroaromatic compounds (12,13,14). A preliminary conversion of a broad range of organic compounds, including lignin, is completed by various soil microbes into two aromatic compounds, namely catechol and protocatechuic acid (12,13). Simple cyclic aromatic hydrocarbons that include EPA priority pollutants including benzene, toluene, and phenol can be metabolized to catechol in the soil medium (11,12). The end products of the b-KAP are acetyl-CoA and succinyl-CoA. Acetyl-CoA generated via the b-KAP can be utilized to produce lipids, cholesterol, ketones and acetylcholine for use in biological

structures or energy (12,13,14). Interestingly, acetyl-CoA is also a precursor to glucose and carbohydrates via the glyoxylate cycle, which although usually absent in animals, is present in plants, bacteria, protists and fungi (15,16).

The multi-dimensionality in the molecular biomolecule synthesis capabilities of acetyl-CoA make it a unique molecule for potential research applications in GSI bioremediation efforts globally. Multiple GSI locations around Santa Fe County are actively growing *Pleurotus* species in rain gardens using Siberian Elm as a substrate for growth.



Two different species of oyster mushrooms (*Pleurotus ostreatus*) growing in a GSI rain garden adjacent to the Santa Fe River.

LIGNIN = WOOD

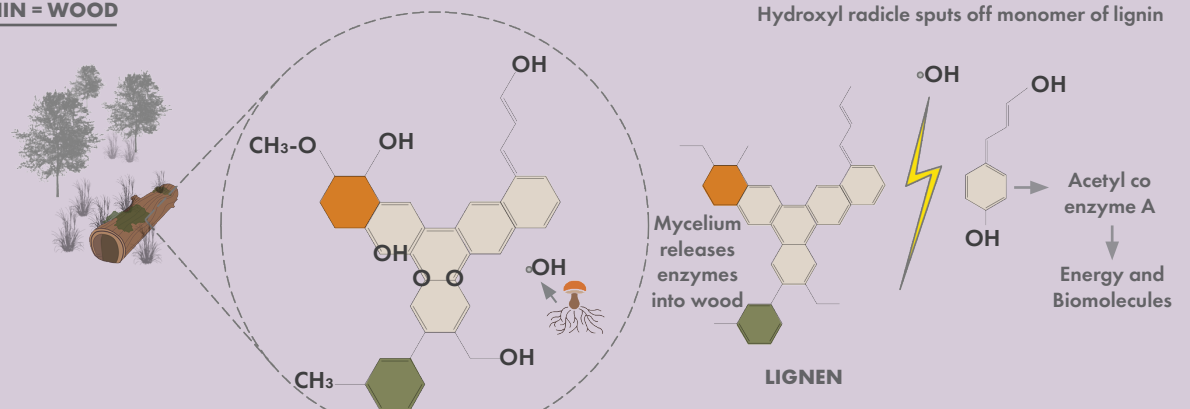

PAH (5 RING) = PETROLEUM (ASPHALT)

Toxic carcinogenic

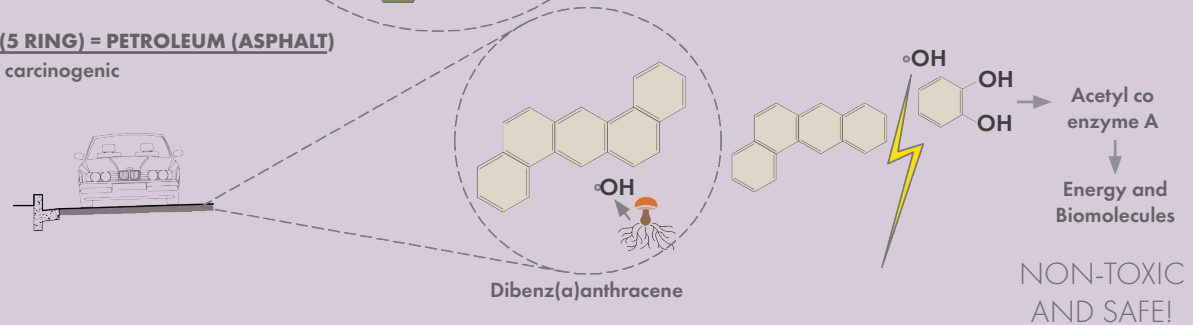

NON-TOXIC AND SAFE!

Diagram demonstrating fungal decomposition at a molecular level.

VEGETATION/FUNGAL COMMUNITIES

VEGETATION

Green stormwater infrastructure can be used to provide passive irrigation and prolong soil moisture for trees and other plants (14). In turn, increased vegetation cover can address urban heat island effect, sequester carbon, clean air, and provide forage for pollinators and other wildlife. There are also a growing number of studies and databases that highlight plants that are tolerant of stormwater pollutants and potentially aid in the remediation of contaminants including heavy metals, petroleum products, nutrients, and more (15,16). Research also indicates that better aesthetics from mature and well-manicured tree canopy around businesses can improve commerce (17). The benefits can add up to the point where they likely exceed the \$1.31 in public tree cover value for every \$1.00 spent on maintenance as determined in a study for the City of Albuquerque (18).

Establishing and maintaining vegetation in GSI features can be challenging however, due to fluctuations in the volume and frequency of stormwater entering a basin. Carefully selecting vegetation capable of living off annual estimated runoff and periods of drought is critical, but it is also worth considering placement of plants in a GSI feature. Situating plants at specific points and elevations within a basin can help them endure and thrive during and between storms or result in insufficient soil moisture, waterlogging, and even rot. The proximity of plants to a GSI inlet, the depth or slope of a basin, the porosity of soil, and interior elevations (e.g. terraces, weirs, etc.) are all factors that could influence water abundance or scarcity.

The following diagram (Figure 24) is intended to aid in vegetation placement based on species water needs and tolerance to saturated, transitional, and dry conditions described below.

Ideal conditions for tree growth usually include moist, well-drained soil. This quality can easily be created through proper soil preparation and a conventional irrigation regime (e.g. drip emitters). Soil moisture conditions in GSI however, can be highly variable depending on the area of contributing runoff, the frequency and depth of storms, seasonal evapotranspiration rates, soil textures/mulches, and other factors. Therefore, the assignment of soil moisture tolerance for trees in this manual relies on a compendium of urban trees capable of more stressful conditions outlined by Cornell University (19). In the study, the authors partitioned soil moisture into four categories including “occasionally saturated or very wet soil; consistently moist, well-drained soil; occasional periods of dry soil; and prolonged periods of dry soil.” The four categories are further partitioned into ranges of 1-3, 4-6, 7-9, and 10-12 respectively.

Given the more extreme evapotranspiration conditions of the Southwest and around impervious development, the score ranges have been adapted to three planting zones in a GSI feature for Santa Fe County. The zones include locations that might experience standing water during even small storms (i.e. saturated), locations that might only inundate the base of plants during larger storms that fill the GSI feature (i.e. transitional), and sites that are adjacent but outside the elevations of where ponding might occur in a GSI feature (i.e.

dry). Trees designated as capable of living in “dry” conditions for this manual must exhibit the ability to live in “prolonged periods of dry soil” from the Cornell study, but it is probably still worth planting them adjacent to regularly irrigated portions of a basin (e.g. terrace immediately above the deepest part of a rain garden).

Tree species that are rated for high water usage should only be used in GSI applications where impervious areas of contributing runoff exceed 7,500sqft and basin volumes are greater than 1,500 gallons. Smaller runoff areas or catchment volumes might not adequately sustain plants during extended periods of drought or more extreme growing conditions from hot surfaces.

As noted by the authors, for any tree to live in less-than-ideal conditions (whether saturated or dry), it is important for the tree to be well established which could mean supplemental watering during the first few years. Table 4 provides a short list of plant and mycelium species that have grown well in GSI features or are believed to be suitable for Santa Fe County.



Water Usage by Plants
(High, Moderate, Low,
Very Low)

Tolerance of
Frequent/Prolonged
Inundation (Saturated,
Transitional, Dry)

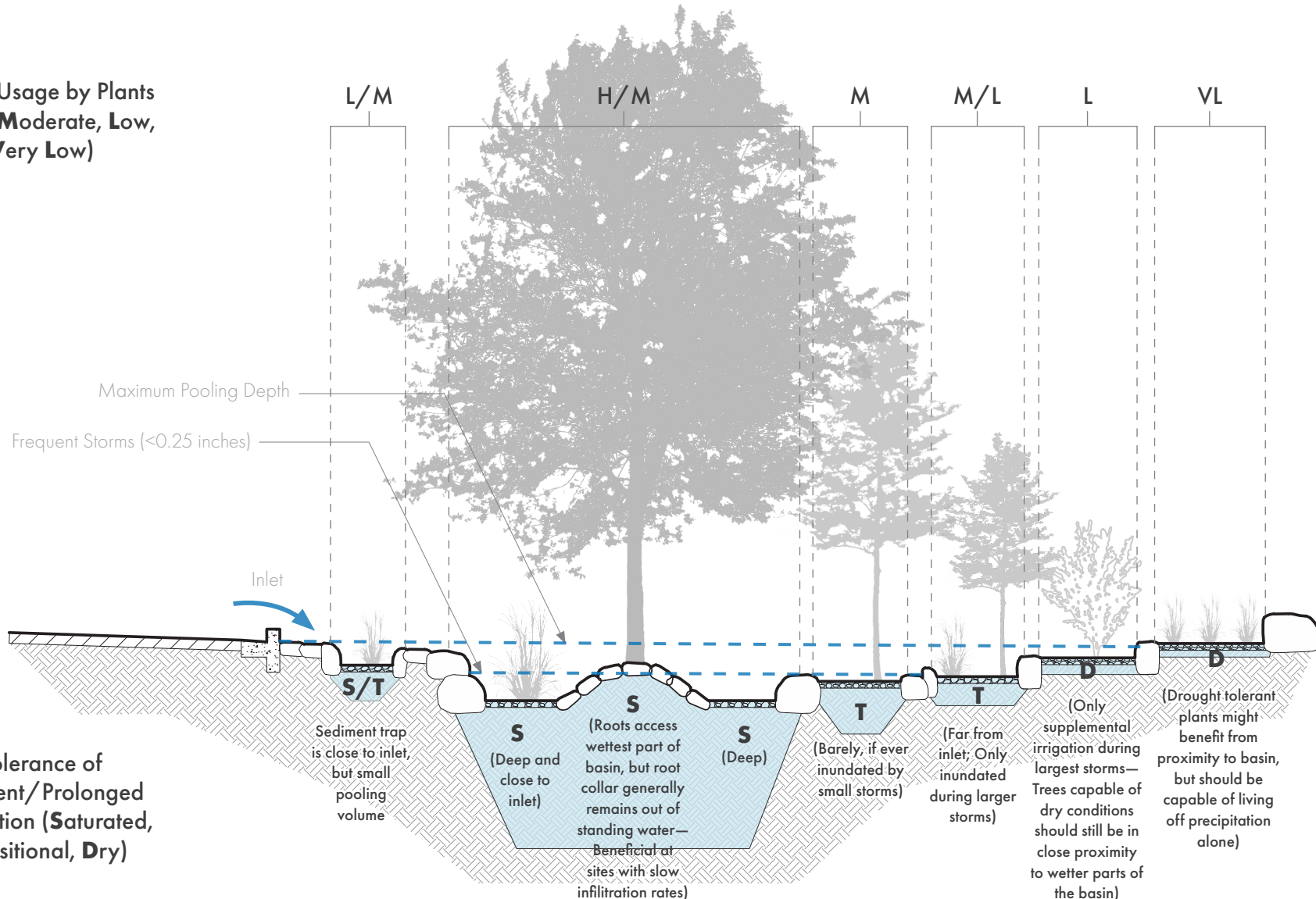

Figure 24. Placement of trees and other vegetation within a GSI feature will influence the establishment and well-being of plants. Deeper parts of the basin will probably have higher and prolonged soil moisture at various depths, but poor infiltration or frequent storms could lead to saturated and anaerobic conditions. Plant tolerance to inundation (Saturated, Transitional, Dry conditions) and water needs (High, Moderate, Low, and Very Low) are important considerations regarding vegetation in GSI features. Water availability in GSI structures will vary depending on the area of contributing runoff and basin dimensions, but it is probably best that rain gardens, bioswales, chicanes, and features other than bioretention basins have less than 12-inches of pooling depth. GSI depths and planting areas could be designed according to pooling from common storms (i.e. typically less than 0.25-inches) to improve irrigation frequency, rare/large storms to replenish soil moisture at higher terraces or further from the inlet, and sites where vegetation should be capable of living off annual precipitation alone.

MYCO-SPONGE

MYCO-SPONGE

Fungi are truly the keystone species to all known ecosystems. Saprophytic fungi, the decomposer fungi, are the interface between life and death in all natural ecosystems and could be described as the “grand molecular disassemblers of nature.” Without the saprophytes, there would be no decay, and therefore no release of important biomolecules and nutrients back into the ecosystem. Saprophytic fungi are the sole, unique organisms that can fully decompose highly complex carbon structures, such as cellulose and lignin (among others). White rot?

All trees and vascular plants are composed of cellulose and lignin, and when they die, these molecules are returned to the soil as bioavailable nutrients via these fungi. In the process of releasing these nutrients, the fungal mycelium (can be thought of as fungal “roots”) are simultaneously hydrating the environment that they are growing into, binding soil particles together, and serving as a food source for other organisms in the soil like arthropods and worms.

Our urban environment is composed of streets, parking lots, and other impermeable surfaces that collect oil/gas, paint, tire particles, asphalt, and biological contaminants such as *E. coli* and coliform bacteria. During rain events, these anthropogenic pollutants are transported into freshwater ecosystems, with minimal capacity for treatment. The unique enzymatic processes that saprophytic fungi utilize to decompose dead plant material makes them model organisms for the breakdown of these pollutants, which are similar in molecular structure to cellulose and lignin. Utilizing saprophytic fungi to remediate stormwater pollutants by adding myco-sponges to GSI features is at the forefront of urban runoff water purification design.



Huge oyster mushroom emerging from a raingarden.



Oyster mushroom fruiting from inoculated Siberian Elm log.



Large oyster mushroom flush—note primordial spawn in back!



Mature oyster mushroom flush in reproductive phase (sporulation evident by white, powdery substance surrounding fruiting body).

MYCO-SPONGE

DEFINITION

A MYCO-SPONGE IS A COMPONENT OF A GSI FEATURE THAT UTILIZES DEAD WOOD LOGS (E.G. SIBERIAN ELM) AS A SUBSTRATE FOR SAPROPHYTIC FUNGAL GROWTH TO AID IN THE REMOVAL AND BREAKDOWN OF URBAN STORMWATER POLLUTANTS.

CRITICAL FEATURES AND PRINCIPLES

Mycosponges can be used anywhere stormwater is captured and can function as both a remediative tool and as a soil moisture resource. Fungi need a substrate to grow on (and into) (i.e. dead logs), and they require sufficient moisture to colonize these substrates. It is vital to follow the size, depth, and inoculation requirements in the construction notes carefully to ensure the fungi have enough moisture to begin growth, as well as to fully establish over time. In keeping with the permaculture principle "the problem is the solution," it is recommended to use the wood of locally invasive tree species (e.g. Siberian Elm) as the substrate, since they grow abundantly and can be replaced with more preferable species over time. *White rot fungi? any restrictions on kind/freshness of wood?

CONSTRUCTION NOTES:

1. Excavate a trench approximately 18" deep, 18" wide, and 4' long.
2. Inoculate 3–4 dead logs (preferably Siberian Elm) per myco-sponge, cut into 30"–36" sections.
3. Drill approximately 50–100 holes per log using 5/16" self-guided drill bit with stop mechanism. Keep holes to bottom 18" of each log (area to be buried) to ensure inoculated portion of log remains covered by soil to maintain moisture.
4. Acquire oyster mushroom (*Pleurotus ostreatus*) plug spawn (inoculated wooden dowels). These are sold commercially and easily available. Ensure that the inoculant is healthy (plugs should be covered in white, vibrant mycelium) before use.
5. Use rubber mallet to install plug spawn into drilled holes.
6. Spread hot wax (paraffin) over new plugs to cover them and protect them from desiccation.
7. Bury logs in newly excavated trench from step 1.
8. Surround logs with 1' deep layer of wood chips or bark mulch. This is the growth medium for the fungal mycelium once it has colonized the log, which will aid its expansion into the soil medium outside the log over time. The more surface area the mycelium can grow into, the more effective it will be at making contact with water, and therefore the removal/degradation of pollutants suspended in it. As the mycelium breaks down the woody medium, it also enhances soil moisture retention and distribution, benefitting surrounding vegetation.
9. Cover wood chips with minimum of 4" coarse sand.
10. Multiple myco-sponges can be installed in a series within a GSI feature to create Induced Meandering to slow stormwater and encourage infiltration. Place myco-sponges flush with wall of GSI feature approximately every 3', alternating sides and leaving a gap of at least 4" between end of myco-sponge and opposite wall to allow water to flow through. This should encourage water to flow in an "S" shape through the basin of the GSI feature.



Mycosponges yielding a cluster of Oyster mushrooms.



Mycosponges in rain garden yielding flushes of 2 different Oyster mushroom species.



KEYED NOTES:

- A. P. Ostreatus inoculated elm logs.
- B. 4" course sand.
- C. 1' wood chips.
- D. Urban Zuni bowl system.

MAINTENANCE NOTES:

- 1) Myco-sponges can be treated the same as new plantings in a GSI feature and should be watered adequately to maintain soil moisture. Supplemental watering may be necessary to ensure they remain moist between storm events. [times a week/metric?]
- 2) Inspect sediment trap of GSI feature utilizing myco-sponge component periodically or after heavy storms, and remove sediment once it has accumulated to 1/2 depth of sediment trap. Stormwater must be able to access the basin to irrigate the myco-sponge(s) in order to keep them alive and growing.
- 3) In some cases, depending on the diameter of the log, full colonization of the substrate can take anywhere between 6 to 18 months. If a log is successfully colonized, mushrooms will begin to "fruit" around this time, appearing periodically in flushes in and around the logs. These mushrooms are not safe to eat, as their surfaces may have come into contact with pollutants carried in stormwater—do not harvest and eat GSI mushrooms! If you do not see any fruiting bodies after this period of time, it may be because the myco-sponge did not receive sufficient moisture. If this is the case, the unsuccessfully colonized logs can be buried as soil amendments and replaced with new inoculated logs.
- 4) Within approximately 3-6 years, the logs will begin to decay and may need to be replaced with new logs.

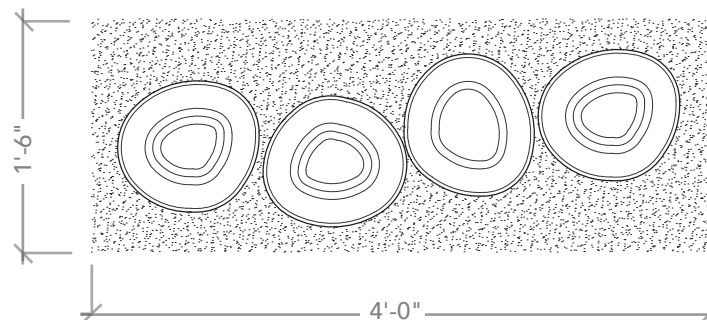

Myco-sponge In Plan

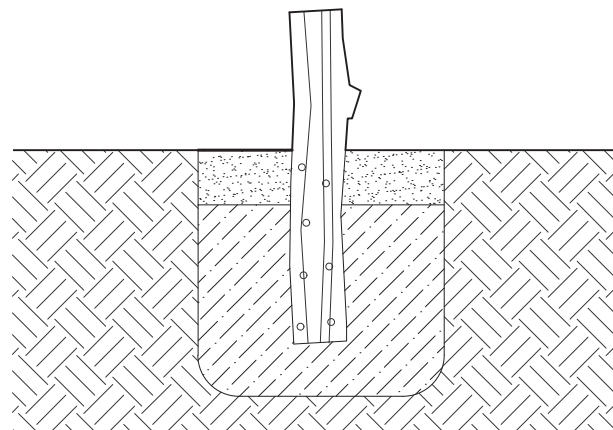

Innoculated Elm Log In Section

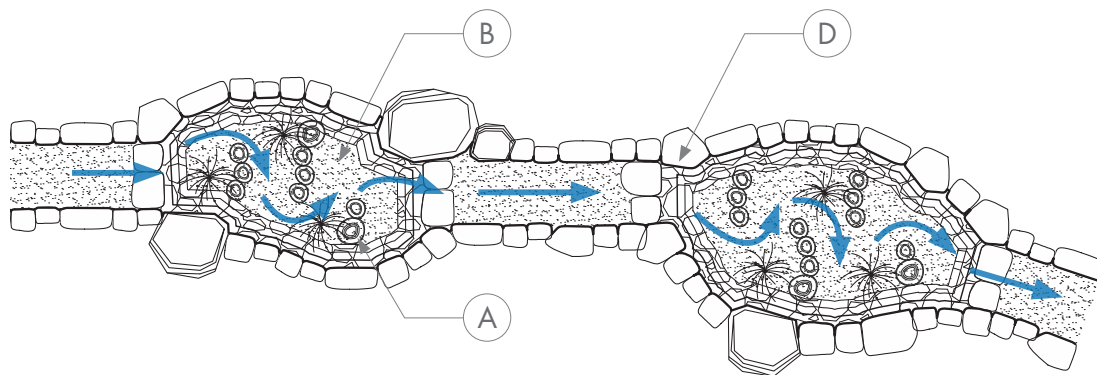

Plan Detail of Myco-sponges used in a series to induce meandering of stormwater in Urban Zuni Bowl rain garden

PLANT INSTALLATION GUIDELINES

DEFINITION

VEGETATION SELECTED FOR ENVIRONMENTAL, COMMERCIAL, AND AESTHETIC BENEFITS IN GSI FEATURES.

CRITICAL FEATURES AND PRINCIPLES

Careful plant selection is crucial to the functionality and viability of a GSI feature including pollutant remediation, habitat improvement, shade production, and aesthetics.

COMMON IMPLEMENTATION MISTAKES:

Selection and placement of plant species that are not tolerant of the excessive or infrequent soil moisture conditions, limited rooting volume, or other challenging conditions in a GSI feature.

CONSTRUCTION NOTES:

Plant Selection:

Consider the following:

1. Water needs, pooling and drought tolerance.
2. Expected mature dimensions (e.g. height, width, rooting volume, etc.).
3. Utility concerns (e.g. overhead powerlines, subsurface powerlines, subsurface sewer lines, etc.). Call local utility companies for free at ___ to locate subsurface utilities prior to construction.
4. Habitat value (e.g. flowering, fruiting, cover, etc.).
5. Pollutant remediation.
6. Pruning or other maintenance requirements (e.g. right-of-way visibility, plant health, dormancy vs imminent danger, etc.).

Plant Installation:

1. Select species and location for planting based on criteria above.
2. Loosen compacted soil (ideally $\geq 3X$ the diameter of root ball, but not significantly deeper than container).
3. Set root collar at elevation according to flood and drought tolerance.
4. Lightly compact surrounding soil with integrated or surficial soil amendments (e.g. compost, woodchips, etc.).
5. Stake trees ≥ 1.5 -inch caliper with three stakes ensuring that tether holds against prevailing wind (typically spring wind direction) and will not girdle or wound the trunk prior to removal.
6. Remove stakes and tethering after two growing seasons.

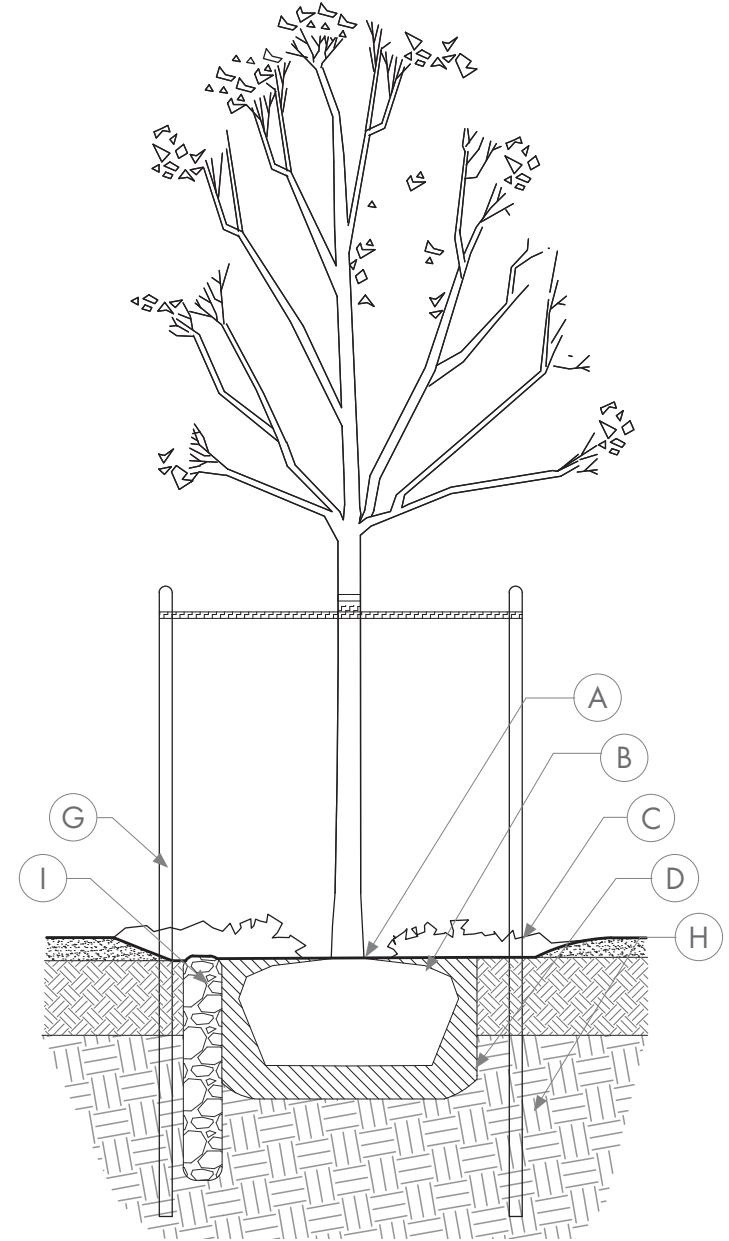

Tree planting diagram



KEYED NOTES:

- A. Root collar of plant slightly higher than adjacent soil grade to prevent where standing water persists.
- B. Remove all metal cages from ball and burlap rootballs before planting.
- C. 2"-3" Shredded bark mulch in 3'-0" diameter around base of tree where stormwater pools (i.e. doesn't flow/erode).
- D. Amend soil as per specifications.
- E. Backfill as per specifications.
- F. Existing subgrade.
- G. 2" metal T-posts 8' long. Position min 18" below bottom of tree hole.
- H. Existing subgrade.
- I. Rock Tube to help infiltrate water.
- J. Mulch as specified.

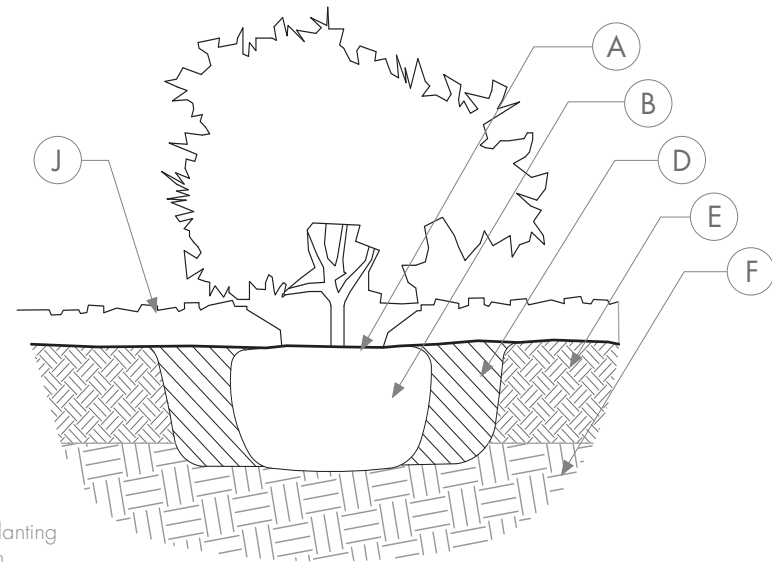

MAINTENANCE NOTES:

- 1) Monitor and irrigate plants during establishment (usually 18-24 months).
- 2) Mow grasses during dormancy to a minimum height of 6 inches and not within 1 foot of shrubs or trees.
- 3) If pruning is necessary, cut limbs during dormancy, unless visibility or other hazards are present.
- 4) Pull, rather than mow, undesired annuals or other invasive plants.
- 5) See maintenance section for more details.

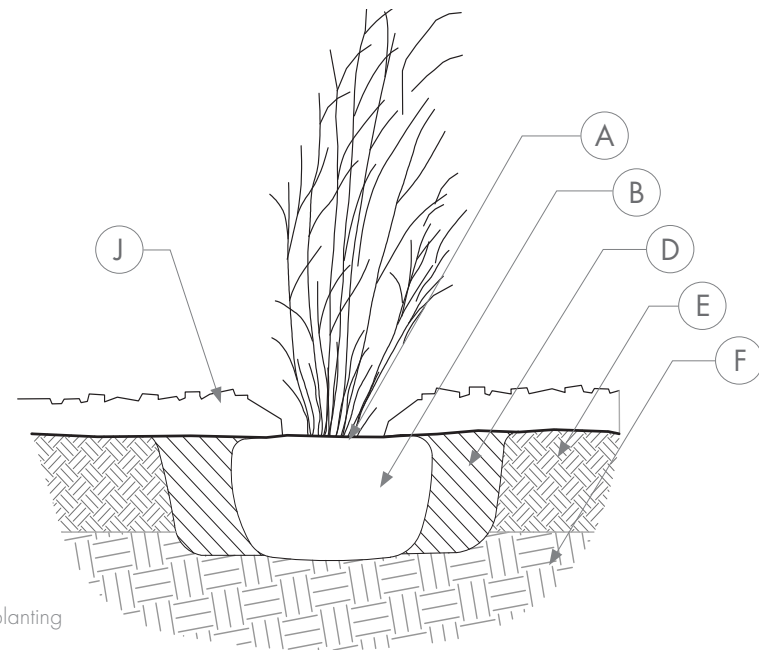



URBAN FORESTRY

The benefits of stormwater capture can be compounded by its movement through biological mediums. Trees play an important role in the overall water cycle by returning water to the atmosphere and regulating water flow to the ground in the form of throughfall and stemflow, which allows more efficient infiltration of stormwater into soils (1,2,3). Trees also condition the soil both physically and chemically. Root action, which allows for greater infiltration and percolation of water through the soil profile, water is transpired out of the soil, freeing up pore space and allowing for increased water holding capacity (1,3). A forested area therefore provides services to an ecosystem that leads to a clean, continuous supply of water for streams that feed rivers and lakes. From an anthropogenic perspective, ecosystem services— aspects of an ecosystem utilized to promote human well-being— as a result of using GSI in urban environments has been shown to impact human health. In a review paper by Suppakittpairarn et al. (2017) it was found that GSI is linked to cardiovascular health, healthier patterns of cortisol secretion, better pregnancy and birth outcomes, and other physical and mental health benefits. Furthermore, urban trees can provide a reduction in air pollution, ultra-violet radiation, and heat exposure and can improve attention restoration, mental health, stress reduction, birth outcomes, immune response, active living, weight status, and cardiovascular disease and function (8).

Another important function of trees in the ecosystem is the concept of hydraulic redistribution (HR)—the process by which water in soil is translocated by plant roots from wet to dry areas as it is drawn through xylem pathways by a water potential gradient (4,9). The term, previously coined “hydraulic lift,” was later renamed when studies found that the process not only moves soil moisture upwards in the soil media, but also downwards and laterally (4). Studies completed in zero transpiration conditions have shown that water can move through the passive conduits of roots and stems in response to any existing water potential gradient, redistributing water in the soil (4,9).

Perhaps even more importantly, it has been shown that hydraulic redistribution (HR) is an important facet in the survival of arid land plant specimen. The propensity for arid land plants and trees to redistribute water, even during dormancy periods, may be an important competitive advantage in regions where monsoonal rains are becoming more uncertain due to climate change (4). Hydraulic redistribution has also shown to help in the decomposition rates of soils in arid lands, releasing important nutrients to the surrounding ecosystem (6). In one study, HR created a diel rhythm of root driven water fluxes and rhizodeposition, where, when added to the drying-rewetting cycles of these climates, showed heightened microbial activity and enhanced decomposition of surrounding litter (6). GSI directly influences the growth of urban forests without the need for supplemental watering.

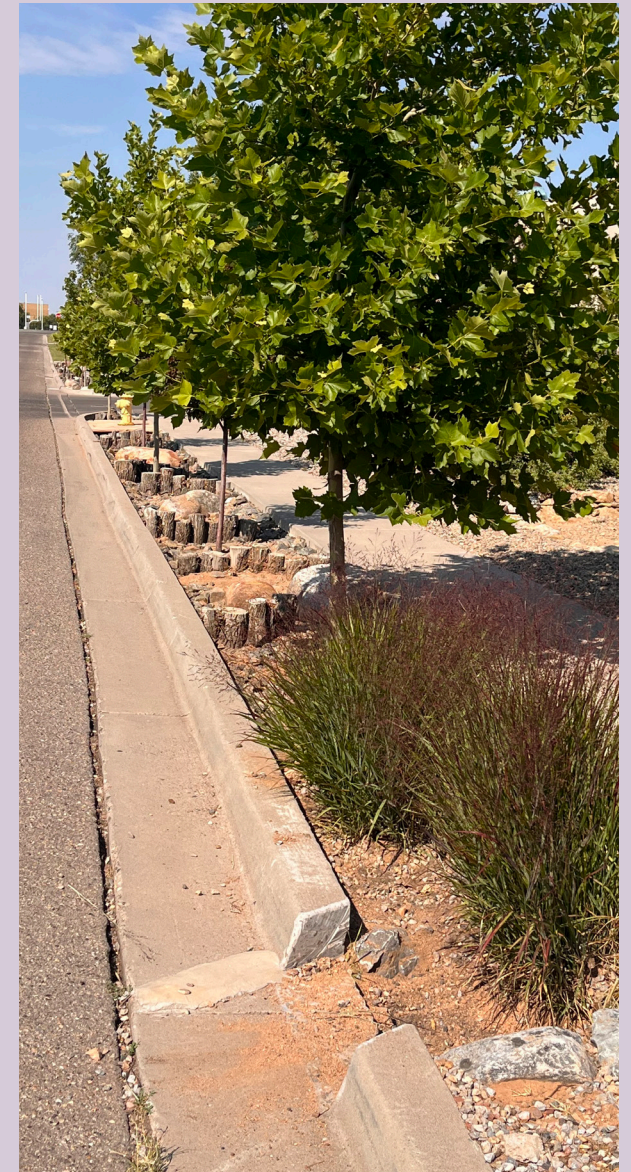

Urban forest created using GSI along the street side.



PHYTOREMEDIATION

Phytoremediation is defined as the direct use of living green plants for the removal, degradation, and containment of contaminants in soils, surface water, and ground water (1). The role of vegetation in bioinfiltration has proven to be critical in the improvement of water quality compared to unvegetated retention basins (1,2,4). Plants can influence pollution removal directly through adsorption and uptake, and indirectly by influencing soil microbial activity via oxygenation of the rhizosphere (4). Stormwater infiltration basins can be prone to clogging via sediment and pollutants. Recent research shows that plants reduce clogging through the creation of macropores through the soil medium (2). Investigations into the accumulation of metals (including copper, lead, and zinc) in stormwater basins indicate that more than 80% of metals accumulate in the soil due to finite sorption capacity and continuous application via storm events (9). Specific plant specimen have been shown to help accumulate these metals, and aid in the removal of PAHs. Eight different species of prairie grass have been found to effectively remove PAHs from soils—including: Big Bluestem, Little Bluestem, Indian Grass, Switch Grass, Canada Wide-rhy, Side Oats Grama, Blue Grama and Western Wheat Grass (5). Prairie grasses like these are thought to make superior vehicles for phytoremediation of PAHs because of their extensive, fibrous root systems (2,5). Grass root systems have the maximum root surface area (per area of soil) of any plant type and may penetrate the soil to a depth of up to 9' (2,5). It is worth noting that most of these species of grasses thrive in GSI projects in Santa Fe County.



Slow movement of springtime stormwater through native grasses in GSI feature.

PLANT LIST

COMMON + SCIENTIFIC NAME	MATURE HEIGHT	MATURE WIDTH	SOIL MOISTURE TOLERANCE	WATER USAGE	EXPOSURE
GRASS / FORBS					
Big Bluestem <i>Andropogon gerardii</i>	5-6 ft	2-3 ft	S	H, M	S, P
Sideoats grama <i>Bouteloua curtipendula</i>	2 ft	1 ft	S, T	M, L	S, P
Buffalo grass <i>Bouteloua dactyloides</i>	<1 ft	NA	S, T, D	L, VL	S
Blue grama <i>Bouteloua gracilis</i>	<1 ft	NA	S, T, D	L, VL	S
Feather reed grass <i>Calamagrostis x acutiflora</i>	3 ft	2 ft	S, T	M	S, P 
Jupiter's beard <i>Centranthus ruber</i>	2 ft	2-3 ft	T	M, L	S, P
Sunflower <i>Helianthus annuus</i>	6 ft	1 ft	D	L	S
Western wheatgrass <i>Pascopyrum smithii</i>	2 ft	NA	S, T	M	S, P
Little bluestem <i>Schizachyrium scoparium</i>	2-3 ft	1 ft	S, T	M, L	S, P 
Indian grass <i>Sorghastrum nutans</i>	4-5 ft	1-2 ft	S, T	M, L	S, P, Sd
Alkali sacaton <i>Sporobolus airoides</i>	3 ft	2 ft	S, T, D	L, VL	S 

KEY: S = Saturated;
T = Transition;
D = Dry

H = High;
M = Medium;
L = Low;
VL = Very Low

S = Full Sun;
P = Partial Shade;
Sd = Shade;
A = Adaptable





CHARACTERISTICS **OTHER PLANT AND MYCELIUM CHARACTERISTICS**

FC, M	Native warm season grass; Moderate water; Deeply rooted; Beautiful fall color; 4-6 feet bunchgrass; Beneficial cover for birds, but can require more maintenance than smaller bunch grasses in rain gardens; Can be cut to 12" during dormancy.
FC, M	Native warm season grass; Low water; Deeply rooted; Beautiful fall color; 2-3 feet bunchgrass; Beneficial cover for birds and food source for butterflies; Good for ORDs, RRs, and MLs
	Native warm season grass; Low water; Low growing; can be used in place of a weed barrier, if other ground cover is manually pulled during the first couple years of establishment; Spreads by seed and stolons (above ground runners).
	Native warm season grass; Low water (Exceptionally drought tolerant); Low growing; can be used in place of a weed barrier, if other ground cover is manually pulled during the first couple years of establishment; Spreads by seed and rhizomes (below ground stems); Can be cut to 6" during dormancy.
B, F	Moderate water; Ornamental bunch grass that has sterile, attractive seed heads; Minimal maintenance required which makes for an excellent choice in rain gardens including sediment traps; Can be cut to 9" during dormancy.
F	Perennial flower; Moderate water needs, but has some drought tolerance after establishment; Can be an attractive plant in rain gardens with stone edges; Can become invasive in some situations due to self seeding; Flowers attract butterflies.
B, F, M	Native; Low water; Tall annual flower should be removed in fall; Food value for small mammals and terrestrial birds.
	Native cool season grass; Slender, but sod-forming in areas with moderate shade (e.g. under larger trees) and moist soils; Avoid using in wetter areas where it might outcompete other grasses; One of the few cool season grasses that might establish under stone.
B, FC	Native warm season grass; Low water; Deeply rooted; Beautiful red/purple fall color; 2-3 feet bunchgrass; Prone to reseeding, but still a great bunch grass for rain gardens, including sediment traps, and other upland erosion mitigation BMPs; Can be cut to 6" during dormancy.
	Native warm season grass; Moderate to low water; Deeply rooted; Bronze seedheads; Larger bunchgrass capable of spreading; Good choice for mulched rain garden edges where tall/thick grass is desired, erosion mitigation is needed, a wilder aesthetic is acceptable, or maintenance is infrequent; Can be cut to 9" during dormancy.
B, M	Native warm season grass; Low water; Deeply rooted; 3 feet bunchgrass with tall, delicate, wispy seedheads; Prone to reseeding, but still a great bunch grass for rain gardens and larger sediment traps; Good choice for upland erosion mitigation BMPs; Can be cut to 9" during dormancy.

B = Berries/Fruit/Seeds;
 F = Flowers;
 E = Evergreen;
 FC = Fall Color;
 M = Maintenance

Table 4. Plant and mycelium list for GSI around Santa Fe County. Species indicated with a plant symbol  have been found to easily establish in GSI around Santa Fe County while other species might be more difficult or untested. It is best to assume that vegetation will probably achieve low-moderate sizes on the mature height/width ranges presented below due to the challenging conditions (e.g. hot/dry impervious surroundings, compacted or poorly drained adjacent soil, irregular irrigation) that plants might experience in GSI features.

PLANT LIST

COMMON + SCIENTIFIC NAME		MATURE HEIGHT	MATURE WIDTH	SOIL MOISTURE TOLERANCE	WATER USAGE	EXPOSURE
SHRUBS						
Indigo bush	<i>Amorpha fruticosa</i>	4-12 ft	6-15 ft	S,T	M, L	S, P 
Lead plant	<i>Amorpha canescens</i>	2-3 ft	2-2.5 ft	T, D	L	S, P
Four-wing saltbush	<i>Atriplex canescens</i>	3-6 ft	2-8 ft	D	L, VL	S
Blue mist spirea	<i>Caryopteris x clandonensis</i>	2-3 ft	3-5 ft	T	L	S 
Alderleaf mountain mahogany	<i>Cercocarpus montanus</i>	8-15 ft	4-8 ft	T, D	L	S
Curl leaf mahogany	<i>Cercocarpus ledifolius</i>	10-20 ft	6-12 ft	T, D	L	S
Fernbush	<i>Chamaebatiaria millefolium</i>	4-5 ft	5-6 ft	T, D	L	S, P
Desert willow	<i>Chilopsis linearis</i>	10-15 ft	8-12 ft	T, D	L, VL	S
Apache plume	<i>Fallugia paradoxa</i>	3-7 ft	4-6 ft	D	L, VL	S
New Mexico privet	<i>Forestiera neomexicana</i>	10-15 ft	8-15 ft	S, T	L	S, P 
Western sand cherry	<i>Prunus besseyi</i>	2-3 ft	4-5 ft	T	L	S
Nanking cherry	<i>Prunus tomentosa</i>	6-10 ft	8-12 ft	T	ML	S, P

KEY:

S = Saturated;
T = Transition;
D = Dry

H = High;
M = Medium;
L = Low;
VL = Very Low

S = Full Sun;
P = Partial Shade;
Sd = Shade;
A = Adaptable





CHARACTERISTICS OTHER PLANT AND MYCELIUM CHARACTERISTICS

F	Large, mounding shrub; Moderate to fast growth rate; Small purple flowers with yellow/orange anther that attract butterflies; Tolerant of wet soils with periods of drought; Nitrogen fixer; Very easy to establish in the bottom of rain gardens.
F	Small, rounded shrub; Slow growth rate; Small purple/blue flowers that attract butterflies; Drought tolerant.
B	Large, mounding silvery semi-evergreen shrub; Moderate growth rate; Offers good refuge for birds during winter; Xeric plant that will happily endure hot dry conditions outside of pooling stormwater.
F	Small, mounded shrub; Slow growth rate; Small powdery blue flowers that attract butterflies and heavily utilized by native, honey, and bumblebees; Prefers moist well drained soil, but is drought tolerant.
B	Broad rounded or vase shaped, semi-evergreen large shrub small tree; Slow growth rate, but long-lived; Flowers are inconspicuous, but fuzzy seed heads are of interest; Drought tolerant.
B, F, E	Moderate sized rounded shrub; Moderate growth rate; Fern-like leaves with small prolific white flowers that attract pollinators; Tolerant of poor soils and drought conditions, but extra water in well drained soil helps.
F	Large shrub (small tree); Moderate growth rate; Beautiful funnel-shaped flowers can range from whitish pink to dark pink; Flowers give way to seed pods in fall which can be somewhat messy; Tolerant of poor soils and hot dry conditions around parking lots and cobble mulches; Soil should drain well if placed in a rain garden.
B, F, M	Large rounded semi-evergreen shrub; Moderate growth rate; Beautiful white flowers with feathery pink seed heads; Can handle transitional water depths in GSI if soils are well drained, but otherwise considered a xeric plant that will happily endure hot dry conditions outside of pooling stormwater.
F	Native shrub that tends to form multiple stems, but can be pruned to a few trunks to appear as a small tree; Moderate growth rate; Female plants produce black fruits that birds will consume; Yellow fall foliage; Drought tolerant.
B, FC	Low growing shrub; Slow growth rate; Small white flowers in spring give way to glossy dark purple/black fruits in summer that are edible; Orange/reddish foliage in fall; Attracts pollinators and birds; Prefers well drained soil; Drought tolerant.
B, F, FC	Narrow and moderate size shrub; Slow growth rate; Light pink/white flowers in spring give way to red fruits in summer; Attracts pollinators and birds; Prefers moist well drained soil.
B, F	Narrow deciduous large shrub/small tree; Moderate growth rate; Prefers moist, but well drained soil; White flowers utilized by insects and red/purple fruit is a good food source for birds; Prone to forming thickets which could necessitate occasional pruning at the base.

B = Berries/Fruit/Seeds;
 F = Flowers;
 E = Evergreen;
 FC = Fall Color;
 M = Maintenance

Table 4. Plant and mycelium list for GSI around Santa Fe County. Species indicated with a plant symbol  have been found to easily establish in GSI around Santa Fe County while other species might be more difficult or untested. It is best to assume that vegetation will probably achieve low-moderate sizes on the mature height/width ranges presented below due to the challenging conditions (e.g. hot/dry impervious surroundings, compacted or poorly drained adjacent soil, irregular irrigation) that plants might experience in GSI features.

PLANT LIST

COMMON + SCIENTIFIC NAME		MATURE HEIGHT	MATURE WIDTH	SOIL MOISTURE TOLERANCE	WATER USAGE	EXPOSURE
SHRUBS / TREES						
Chokecherry	<i>Prunus virginiana</i>	12-18 ft	8-15 ft	S,T	M	S, P
Fragrant sumac	<i>Rhus aromatica 'gro-low'</i>	1.5-2 ft	6-10 ft	T, D	L, VL	S, P 
Three-leaf sumac	<i>Rhus trilobata</i>	4-6 ft	6-10 ft	T, D	L, VL	S, P 
Golden currant	<i>Ribes aureum</i>	4-5 ft	4-5 ft	S, T	M, L	P
Sensation Boxelder	<i>Acer negundo 'Sensation'</i>	30-40 ft	30-40 ft	S, T	M, L	S
Northern Catalpa	<i>Catalpa speciosa</i>	40-50 ft	25-40 ft	S, T	M, L	S, P
Western Hackberry	<i>Celtis occidentalis</i>	40-50 ft	40-50 ft	T	M, L	S
Magnifica Hackberry	<i>Celtis occidentalis 'Magnifica'</i>	40-50 ft	40-50 ft	T	M, L	S
Eastern Redbud	<i>Cercis canadensis</i>	20-25 ft	25-30 ft	T	M, L	S, P
Russian Hawthorne	<i>Crataegus ambigua</i>	18-25 ft	25-30 ft	T	M, L	S
Patmore Ash	<i>Fraxinus pennsylvannica 'Patmore'</i>	50-70 ft	35-45 ft	S, T	M, L	S 

KEY: S = Saturated;
T = Transition;
D = Dry

H = High;
M = Medium;
L = Low;
VL = Very Low

S = Full Sun;
P = Partial Shade;
Sd = Shade;
A = Adaptable



CHARACTERISTICS **OTHER PLANT AND MYCELIUM CHARACTERISTICS**

B, F, FC, M	Narrow deciduous large shrub/small tree; Moderate growth rate; Prefers moist, but well drained soil; White flowers utilized by insects and red/purple fruit is a good food source for birds; Prone to forming thickets which could necessitate occasional pruning at the base.
B, F, FC	Short, creeping alternative to Three-leaf sumac; Moderate growth rate; Flowers attract pollinators; Excellent red fall color; Can withstand heavy watering as long as soils drain well; Drought tolerant.
B, F, FC	Moderate, rounded shrub although low or creeping variations exist; Moderate growth rate; Mild skunk aroma if brushed against; Flowers attract pollinators in spring; Small fuzzy, red fruits; Orange/red fall foliage; Can withstand heavy watering as long as soils drain well; Drought tolerant.
B, F, FC	Small shrub; Slow/Moderate growth rate; Yellow flowers give way to glossy dark purple fruits; Prefers shade and moist, well-drained soils, but will tolerate periods of drought.
FC	Rounded/upright shape; Moderate to fast growth rate; Green maple-shaped leaves with red tips on new growth in the summer that ultimately shift to bronze in the fall; Prefers moist soil, but tolerant of drought and other poor soil conditions; Seedless male cultivar reduces proliferation of box elder bugs.
F	Oval shape; Moderate growth rate; Showy tree with large heart-shaped leaves and white flowers in spring; Tolerant of wet or dry soils; Bees and hummingbirds take advantage of flowers; Seeds dangle as large pods.
B, FC	Rounded shape; Moderate growth rate; Rough bark with leaves that are often infested with hackberry psyllids, which don't harm the tree; Leaves are utilized by butterfly larvae such as mourning cloaks; Produces small dark red drupes that birds eat; Tolerant of wet/dry soils; Leaves turn yellow in fall.
B, FC	Irregular, arching shape; Moderate growth rate; Highly adaptable; Rough bark; Disease and pest resistant (more so than <i>Celtis occidentalis</i>); Beautiful cork bark is a stand out feature; White-green blooms emerge in late spring; Produces small dark red drupes that birds eat (does not produce as much as <i>Celtis occidentalis</i>).
F, M	Rounded/broad shape; Moderate growth rate; Renowned for pink flowers in spring that some early butterflies will visit; Leaves are heart-shaped; Seedpod production late in year can be messy on mature trees; Drought tolerant.
F, B, FC, M	Broad, arching shape; Moderate growth rate; Renowned for clusters of white flowers in spring that become red fruit in the fall (beloved by birds), ultimately showcasing a golden fall color; 1/4 - 1/2" long thorns line the upright branches; Drought tolerant.
FC	Broadly pyramidal; Moderate growth rate; Hardy shade tree tolerant of a variety of soils and dry/wet conditions; Leaves turn yellow in fall; Susceptible to Emerald Ash Borer; No seed production. *The potential migration of the emerald ash borer from Colorado could devastate Ash tree populations in the future, plant with caution.



B = Berries/Fruit/Seeds;
 F = Flowers;
 E = Evergreen;
 FC = Fall Color;
 M = Maintenance

Table 4. Plant and mycelium list for GSI around Santa Fe County. Species indicated with a plant symbol  have been found to easily establish in GSI around Santa Fe County while other species might be more difficult or untested. It is best to assume that vegetation will probably achieve low-moderate sizes on the mature height/width ranges presented below due to the challenging conditions (e.g. hot/dry impervious surroundings, compacted or poorly drained adjacent soil, irregular irrigation) that plants might experience in GSI features.

PLANT LIST

COMMON + SCIENTIFIC NAME MATURE HEIGHT MATURE WIDTH SOIL MOISTURE TOLERANCE WATER USAGE EXPOSURE

TREES

Urbanite Ash	<i>Fraxinus pennsylvannica</i> 'Urbanite'	50-60 ft	30-45 ft	S, T	M, L	S	
Modesto Ash	<i>Fraxinus velutina</i>	30-50 ft	45-60 ft	S, T	M, L	S	
Kentucky Coffee	<i>Gymnocladus dioica</i>	18-25 ft	25-30 ft	S, T, D	M, L	S	
Imperial honeylocust	<i>Gleditsia triacanthos</i> 'Imperial' or 'Impcole'	25-35 ft	25-35 ft	S, T, D	L	S	
Shademaster honeylocust	<i>Gleditsia triacanthos</i> 'Shademaster'	40-50 ft	40-50 ft	S, T, D	L	S	
Golden Rain Tree	<i>Koelreuteria paniculata</i>	25-30 ft	30-40 ft	S, T, D	L	S	
White Shield Osage Orange	<i>Maclura pomifera</i> 'White Shield'	30-35 ft	30-35 ft	S, T, D	M, L	S	
Prairiefire Crabapple	<i>Malus</i> 'Prairiefire'	15-20 ft	15-20 ft	T	M, L	S	

KEY: S = Saturated;
T = Transition;
D = Dry

H = High;
M = Medium;
L = Low;
VL = Very Low

S = Full Sun;
P = Partial Shade;
Sd = Shade;
A = Adaptable



CHARACTERISTICS **OTHER PLANT AND MYCELIUM CHARACTERISTICS**

FC	Urbanite ash is typically listed as a green ash (<i>F. pennsylvannica</i>), but is probably a white ash (<i>F. americana</i>); Broadly pyramidal; Moderate growth rate; Probably the hardiest green ash cultivar for hot/urban settings; Tolerant of a variety of soils and dry/wet conditions; Leaves turn bronze in fall; Susceptible to Emerald Ash Borer; No seed production. *The potential migration of the emerald ash borer from Colorado could devastate Ash tree populations in the future, plant with caution.
B, M	Rounded shape; Fast growth rate; Drought and heat tolerant; Can have weak branch structure, is susceptible to pests (e.g. bores and verticillium); Native to the Southwest US. *The potential migration of the emerald ash borer from Colorado could devastate Ash tree populations in the future, plant with caution.
B, FC, M	Irregular, round shape; slow growing, very adaptable; Commonly used as a street tree due to it's tolerance of pollution and toughness. Espresso is the preferable variety (male form).
B, FC	Rounded shape; Moderate growth rate; Thornless, smaller in stature, and probably the most drought tolerant among honeylocust cultivars; Small yellow leaves in fall; Sometimes produces seed pods; Probably the most adaptable tree species for GSI around Santa Fe County, although overuse in other parts of the country has caused some pest problems; Do not plant near established trees that are infested with honeylocust borer.
FC	Vase shape; Moderate/Fast growth rate; Thornless and faster/taller growing than other honeylocust cultivars; Small yellow leaves in fall; Probably the most adaptable tree species for GSI around Santa Fe County, although overuse in other parts of the country has caused some pest problems; Do not plant near established trees that are infested with honeylocust borer.
F, FC	Rounded shape; Moderate/Fast growth rate; Bright yellow clusters of flowers in spring that change into seed pods that can be messy in fall; Yellow foliage in fall; Tolerant of hot conditions common in parking lots; Might survive smaller rooting areas than other comparable size trees; Often infested with seed-eating Golden Rain Tree bugs.
FC,	Rounded shape; Fast growth rate; Thornless and fruitless; Glossy green leaves become yellow foliage in fall; Tolerant of hot conditions common in parking lots; Effective as a windbreak; Adaptable and tough.
B, F	Rounded shape; Slow/Moderate growth rate; Electric pink flowers in spring and reddish green foliage during the growing season; 1/2-inch red fruit is consumed by birds; Good in small medians or under powerlines.

B = Berries/Fruit/Seeds;
 F = Flowers;
 E = Evergreen;
 FC = Fall Color;
 M = Maintenance

Table 4. Plant and mycelium list for GSI around Santa Fe County. Species indicated with a plant symbol  have been found to easily establish in GSI around Santa Fe County while other species might be more difficult or untested. It is best to assume that vegetation will probably achieve low-moderate sizes on the mature height/width ranges presented below due to the challenging conditions (e.g. hot/dry impervious surroundings, compacted or poorly drained adjacent soil, irregular irrigation) that plants might experience in GSI features.

PLANT LIST

COMMON + SCIENTIFIC NAME MATURE HEIGHT MATURE WIDTH SOIL MOISTURE TOLERANCE WATER USAGE EXPOSURE

TREES

Mulberry	<i>Morus alba</i>	30-40 ft	30-40 ft	S, T	M	S, P
London Planetree	<i>Platanus x acerifolia</i>	45-55 ft	35-45 ft	S, T	H, M	S
Rio Grande Cottonwood	<i>Populus deltoides (Wislizenii)</i>	50-60 ft	50-60 ft	S, T	H, M	S
Aristocrat Callery Pear	<i>Pyrus calleryana 'Aristocrat'</i>	25-35 ft	20-25 ft	S, T, D	M	S
Swamp White Oak	<i>Quercus bicolor</i>	50-60 ft	50-60 ft	S, T, D	M, L	S
Chinkapin Oak	<i>Quercus muehlenbergii</i>	40-50 ft	35-45 ft	T, D	L	S
Princeton Elm	<i>Ulmus americana</i>	50-60 ft	30-40 ft	S, T	M	S
Frontier Elm	<i>Ulmus 'Frontier' (U. minor x U. parvifolia)</i>	30-40 ft	20-30 ft	S, T, D	L	S, P
Accolade Elm	<i>Ulmus japonica x Ulmus wilsoniana 'Morton'</i>	40-50 ft	30-40 ft	S, T	M, L	S



KEY:

S = Saturated;
T = Transition;
D = Dry

H = High;
M = Medium;
L = Low;
VL = Very Low

S = Full Sun;
P = Partial Shade;
Sd = Shade;
A = Adaptable



CHARACTERISTICS OTHER PLANT AND MYCELIUM CHARACTERISTICS

B,M	Rounded shape; Moderate growth rate; Fruit can be messy, but it is edible and loved by birds; Fruitless varieties are available; Large glossy leaves provide dense shade which is enhanced by the broadness of mature trees; Leaves tend to drop all at once in fall after first frost; Drought tolerant.
B, FC, M	Commonly referred to as a sycamore; Pyramid to rounded shape; Moderate/Fast growth rate; Foliage is not remarkable, but the bark on these trees include a wonderful palette of exfoliating colors; Neither “Bloodgood” or “Exclamation” have demonstrated great tolerance to hot/dry conditions associated with dense asphalt parking or extreme summers and therefore should only be planted in broad medians where large areas of runoff (>10,000sqft) can be captured to replenish soil moisture; Seed pods can be messy in the fall.
FC, M	Broad crown shape; Fast growth rate; Yellow/Gold foliage in fall; An excellent tree for shade that shows remarkable tolerance/remediation to many pollutants; While moderately drought tolerant, limbs can die back and become vulnerable to breaking in high winds; Should only be planted where large areas of runoff (>10,000sqft) can be captured to replenish soil moisture.
B, F, FC	Pyramid/Rounded shape; Moderate growth rate; Yellow/Orange foliage in fall; Good tree for smaller medians; Literature suggests drought and salt tolerance, but plantings in Santa Fe have struggled during hot/dry spring conditions with burnt leaves; Cultivar can be vulnerable to fire blight; Chanticleer might be a better cultivar as it is resistant to fire blight.
B, FC	Broad/Oval shape; Slow/Moderate growth rate; Yellow foliage in fall; Considered to be fast growing among oak species with large leaves; Susceptible to chlorosis (in more alkaline soils) as well anthracnose.
B, FC	Rounded shape at maturity; Slow growth rate; Dark green leaves in summer with Yellow/Orange foliage in fall; While not a fast growing tree, this species is tolerant of challenging conditions around streets/parking lots and drought; Acorns could be a unique wildlife food source in less urban areas.
FC	Vase shape; Fast growth rate; Yellow foliage in fall; An American elm that is resistant to Dutch elm disease; Capable of growing 3-6 feet per year, this tree could be a good alternative to cottonwoods due to better drought tolerance, but would benefit from >5,000sqft of impervious runoff.
FC	Vase shape; Moderate/Fast growth rate; Red/Purple foliage in fall; Excellent tree under powerlines or in hot/dry conditions around parking lots or streets; Resistant to Dutch elm disease, but moderate resistance to elm leaf beetle; No seed production.
FC	Upright/Vase shape; Moderate/Fast growth rate; Yellow foliage in fall; Resistant to Dutch elm disease.

B = Berries/Fruit/Seeds;
 F = Flowers;
 E = Evergreen;
 FC = Fall Color;
 M = Maintenance

Table 4. Plant and mycelium list for GSI around Santa Fe County. Species indicated with a plant symbol  have been found to easily establish in GSI around Santa Fe County while other species might be more difficult or untested. It is best to assume that vegetation will probably achieve low-moderate sizes on the mature height/width ranges presented below due to the challenging conditions (e.g. hot/dry impervious surroundings, compacted or poorly drained adjacent soil, irregular irrigation) that plants might experience in GSI features.

PLANT LIST

COMMON + SCIENTIFIC NAME MATURE HEIGHT MATURE WIDTH SOIL MOISTURE TOLERANCE WATER USAGE EXPOSURE

TREES

Lacebark Elm	<i>Ulmus parvifolia</i>	40-50 ft	35-45 ft	T, D	L	S, P 
Japanese Zelkova	<i>Zelkova serrata</i>	40-50 ft	35-45 ft	S, T, D	M, L	S

FUNGI

Oyster Mushroom	<i>Pleurotus ostreatus</i>	NA	NA	NA	NA	Subterranean
Turkey Tail Mushroom	<i>Trametes versicolor</i>	NA	NA	NA	NA	Subterranean

KEY: S = Saturated; H = High; S = Full Sun;
 T = Transition; M = Medium; P = Partial Shade;
 D = Dry L = Low; Sd = Shade;
 VL = Very Low A = Adaptable



CHARACTERISTICS **OTHER PLANT AND MYCELIUM CHARACTERISTICS**

FC Rounded shape; Moderate/Fast growth rate; Yellow foliage in fall; Bark exfoliates with mottled colors; Leaves attractive to mourning cloak and other butterfly larvae; Late flowering time supports pollinators; Excellent street tree; Resistant to Dutch elm disease; Some seed production, but not invasive like Siberian elm (U. pumila).

B, FC, M Rounded to vase shaped; Moderate growth rate; Range of fall foliage colors from Brown to Red; Ornamental exfoliating bark; Known to be a good street tree, but narrow branch angles can be susceptible to breaking; Use improved cultivars.

B, FC Known as White Rot Fungi (WRF). These are saprophytic fungi that are uniquely capable of breaking down complex carbon structures such as lignin, cellulose, hemicellulose and pectins in wood. Due to their ability to break down these carbon matrixes, they are also known in the literature to break down PAHs, phthalates, and microplastics. Mycelium should be directly inoculated into dead wood substrates (logs of elm, cottonwood, locust, ash, etc.) and wood substrates buried into the ground. Saprophytic fungal mycelial growth releases nutrients from wood and above mentioned pollutants, and hydrates the soil medium that it grows through.

FC Known as White Rot Fungi (WRF). These are saprophytic fungi that are uniquely capable of breaking down complex carbon structures such as lignin, cellulose, hemicellulose and pectins in wood. Due to their ability to break down these carbon matrixes, they are also known in the literature to break down PAHs, phthalates, and microplastics. Mycelium should be directly inoculated into dead wood substrates (logs of elm, cottonwood, locust, ash, etc.) and wood substrates buried into the ground. Saprophytic fungal mycelial growth releases nutrients from wood and above mentioned pollutants, and hydrates the soil medium that it grows through.

B = Berries/Fruit/Seeds;
 F = Flowers;
 E = Evergreen;
 FC = Fall Color;
 M = Maintenance

Table 4. Plant and mycelium list for GSI around Santa Fe County. Species indicated with a plant symbol  have been found to easily establish in GSI around Santa Fe County while other species might be more difficult or untested. It is best to assume that vegetation will probably achieve low-moderate sizes on the mature height/width ranges presented below due to the challenging conditions (e.g. hot/dry impervious surroundings, compacted or poorly drained adjacent soil, irregular irrigation) that plants might experience in GSI features.

MAINTENANCE

GENERAL MAINTENANCE AND MONITORING

GSI requires periodic review and maintenance to ensure functionality. At sites with upland structures, BMP components should be assessed for failure after initial storms and to ensure colonization by grasses or other vegetation over time. These components can also be examined to determine if adding more structures (e.g. lifting elevation of one rock dams, broadening a media luna, etc.) would be beneficial. Gutters feeding pumice wicks should be regularly cleaned of debris to ensure sediment does not plug subsurface porosity and permeable pavements should be cleared of sediment according to manufacturer recommendations.

In GSI basins such as rain gardens, the most common maintenance will revolve around sediment, irrigation, and vegetation management (Figure 24). Sediment traps will need long-term attention with the frequency of visits dependent on trap dimensions and sediment sources. Vegetation planted in rain gardens or other pooling GSI typically needs to be irrigated for the first 18-24 months until plants are established. The most challenging period for plants is usually in late spring after a dry winter and early summer before the monsoon season. Pruning perennial vegetation is probably unnecessary, but can be done if plants obstruct traffic signs, impede traffic, or encroach too closely to above ground utilities. The New Mexico Department of Transportation has done a good job of compiling GSI maintenance review and tasks in the form of a field guide checklist (22). The field guide can be easily utilized at GSI sites with tasks broken down into levels of effort ranging from visual inspection to more comprehensive remediation needed to ensure functionality and aesthetics.

Some of the most common inspections and follow-up actions include:

- Removing impediments to flow through inlets and outlets
- Cleaning sediment accumulation in traps or inside the general basin
- Mitigating erosion and mulching bare soil
- Disposing of trash or other debris
- Determine if there is prolonged standing water (>48 hours) or evidence of mosquito breeding
- Manage dead, diseased, or damaged plants
- Assess and remediate the presence of pests or other invasive species
- Flag and correct public hazards (e.g. heaved pavement)
- Evaluate and appropriately proceed if there is need for mowing/pruning

Each visual concern has recommendations for remediation, some of which can be completed immediately while others might be best treated by a follow-up visit. The inspection manual includes a calendar for maintenance that varies by season (e.g. pruning during dormancy). Vegetation management, particularly pruning and mowing, is probably the most underappreciated aspect of GSI maintenance. It is important to remember that vegetation in GSI functions and appears different from other landscaping archetypes such as xeriscaping, recreational parks, and traditional roadside or parking lot medians. For instance, GSI vegetation is often selected for pollutant removal and habitat improvement. This could result in the

selection of less common species that are maintained as rich, dense, and less manicured conditions that pollinators might prefer. The widespread amendments to soil intended to improve porosity and nutrients, coupled with infrequent and sometimes overwhelming irrigation from stormwater runoff, could also affect vegetation growth and recruitment not common in other landscaping styles. The result is an aesthetic that might appear wilder or unkempt, more weed infested, and stunted or slower growing. Too often, the response by maintenance crews is to heavily mow during the wrong season, too low to the ground, and too close to perennial shrubs and trees. The consequence is the loss of immature seed heads from plants that provide long-term stability and recruitment at the site (e.g. grasses), the aiding of undesirable low-growing plants that escape cutting (e.g. goatheads, bindweed), and the wounding of bark and cambium that protects the shrub/tree and facilitates nutrient transport. With these concerns in mind, GSI vegetation maintenance should consider:

- Adjust aesthetic expectations through signage, tours, and training for landscaping maintenance crews and the community at large.
- Ensure mowing height for specific perennial grasses, particularly bunch grasses, never dips below 6-inches. This could mean that some grasses (e.g. buffalo grass and blue grama) are rarely, if ever, cut.
- Do not mow grasses or forbs within 1-foot of shrubs/trees.
- Pull, rather than mow, undesired annuals or other invasive plants (e.g. young Siberian elm).
- Remove vegetation between June-September (i.e. when plants are out of dormancy and dead vegetation is obvious).
- Leave plants in place if uncertain whether they are invasive or intended as part of the GSI feature.



Sediment and debris built up at the inlet of a GSI feature due to lack of maintenance.



Consequence of sediment and debris build up: water cannot enter GSI feature.



A young shrub mistakenly cut during dormancy.



Neglected maintenance and absence of sediment trap result in soil build up that surpasses inlet elevation, blocking water from entering GSI feature.

WILDFIRE DEFENSABLE SPACE

FIRESCAPING WITH GSI AND VEGETATION

Firestorming is an intentional way of approaching landscape design that aims to reduce a home and its surrounding property's vulnerability to wildfire. Several key elements and techniques include strategic selection and placement of plants, tree brush/understory maintenance hardscape buffer zones, and eliminating combustable materials within 5 feet of the home.

Though vegetation on a site is commonly one of the last elements to catch fire (materials of the built environment are significantly more flammable), vegetation can easily carry fire long distances when an uncontrolled burn begins raging out of control. By implementing the landscape management practices and design techniques detailed on the following pages, you can significantly reduce your property's chances of being destroyed in a fire.

Fire is an essential and natural part of the southwest ecosystem, as well as being part of the life cycle of many native plant specimen. The longer fires are delayed, the greater propensity they have to rage out of control. Employing controlled burns to burn off diseased or struggling plant matter and implementing these maintenance techniques can help make the ecosystem on your property more resilient, and therefore more resistant to fire. This is actually the best fire prevention method of all! Still, we do have dry seasons in the Southwest, and it is important to keep your home and property as protected as possible in the event of large scale environmental wildfires. Fire preparedness also helps firefighters perform their jobs safely while allowing fire to take its natural

course in the ecosystem. Being a good steward of the land around you and catching and infiltrating water into the Earth and aquifer makes all of our ecosystems more resilient! Passive stormwater catchment in rain gardens near buildings and homes can have numerous benefits including improved soil moisture for plants that help cool/shade. Healthy soil and habitats provide lower wildfire risk. The Wildland Urban Interface (WUI), areas where human development meets undeveloped wildlands, is considered to be an area that is more vulnerable and prone to fire. There are various local resources regarding the management of fuels in the WUI including defensible space, fire resistant plants, etc. These resources can be used in context with Green Stormwater Infrastructure design (e.g. rain gardens) to appropriately locate passive stormwater catchment from rooftops and other impervious surfaces. Some design factors worth considering include:

- Distance of a rain garden from a home/building in accordance with expected mature tree size.
- Distance of a rain garden from a home/building depending on surrounding slopes.
- Maintenance (e.g. pruning and raking) of dry or dead fuels in a basin (e.g. dormant bunch grasses, lower branches or other ladder fuels, etc.).
- Selection and spacing of plant species less prone to fire (e.g. deciduous vs conifers).

RECOMMENDED PLANTS

Though rainfall is unpredictable throughout Santa Fe County and averages are reported to be

approximately 11" annually, many appropriate and drought tolerant plant choices are available for Xeriscaping, or low water-use, mainly native plant gardens. The most important consideration homeowners and building owners need to make is to first identify the area of wildfire risk in the WUI map: <http://santafecountynm.maps.arcgis.com/apps/MapSeries/index>.

Energy, Minerals, and Natural Resources Department (EMNRD) and New Mexico State University provides detailed information on plant choice at: www.emnrd.nm.gov/sfd/wp-content/uploads/sites/4/FireWisePlantMaterialsNMSU.pdf

- Firewise perennials: bergamot, foxglove penstemon, prairie coneflower, thyme, rocky mountain zinnia
- Firewise shrubs: false indigo, dwarf mountain mahogany, rabbitbrush, apache plume, golden currant
- Firewise trees: desert willow, netleaf hackberry, red mahonia, bitter cherry, soap tree yucca

FIREWISE LANDSCAPING

- Designing Firewise landscaping in accordance with the zones for defensible space depends upon risk level.
- Higher fire risk locations and insurance requirements will dictate stringency of Firewise guidelines.
- Each home or building owner will need to take the location and local requirements into consideration for creating their best defense given the risk and benefits.

FIRESCAPING ZONES

Zone 1 (0-5 feet): Immediate Structure Protection

Focus: Protecting the home and its immediate surroundings by only using non-combustible materials in this zone.

Other Considerations: Remove all vegetation within 5' of the building. Check and clean roof gutters on all structures seasonally to remove debris that could become flammable.

Zone 2 (5-30 feet): Intermediate Lean, Clean, and Green

Focus: Maintaining a well-maintained, green area to slow the spread of fire with fire-resistant landscaping materials.

Other considerations: Consider tree and shrub spacing (vertical and horizontal clearances). Remove tree branches within 15 feet of a chimney. Store firewood and other flammable materials 30-50 feet from buildings, garage, or deck. Trim all over-hanging branches from the roof to a minimum of 10 feet away.

Zone 3 (30-100 feet): Extended

Focus: Fuel reduction and fuel breaks to reduce fire risk, including maintenance of grass, tree pruning and ladder fuel removal.

Other Considerations: Keep grass and wildflowers under 4 inches in height. Create "islands" of vegetation to break up continuous fuel ladders. Trees should be thinned and spaced at least 10-15' apart .



A New Mexico forest after being ravaged by fire.



New, healthy growth resurfacing after a forest fire— evidence of ecosystem resilience!

Creating a defensible space around your home is one of the most important and effective steps you can take to protect you, your family and your home from catastrophic wildfire. Defensible space is the area between a structure and an oncoming wildfire (or between a burning structure and wildland vegetation) where nearby vegetation has been modified to reduce a wildfire's intensity.

—NMSU Cooperative Extension Office

EMNRD Forestry Division Brief Facts...

1. *Fire Wise landscaping can be aesthetically pleasing while reducing potential wildfire fuel.*
2. *Plant choice, spacing and maintenance are critical.*
3. *Your landscape and the plants in it must be maintained to retain their Fire Wise properties*

WILDFIRE DEFENSIBLE SPACE

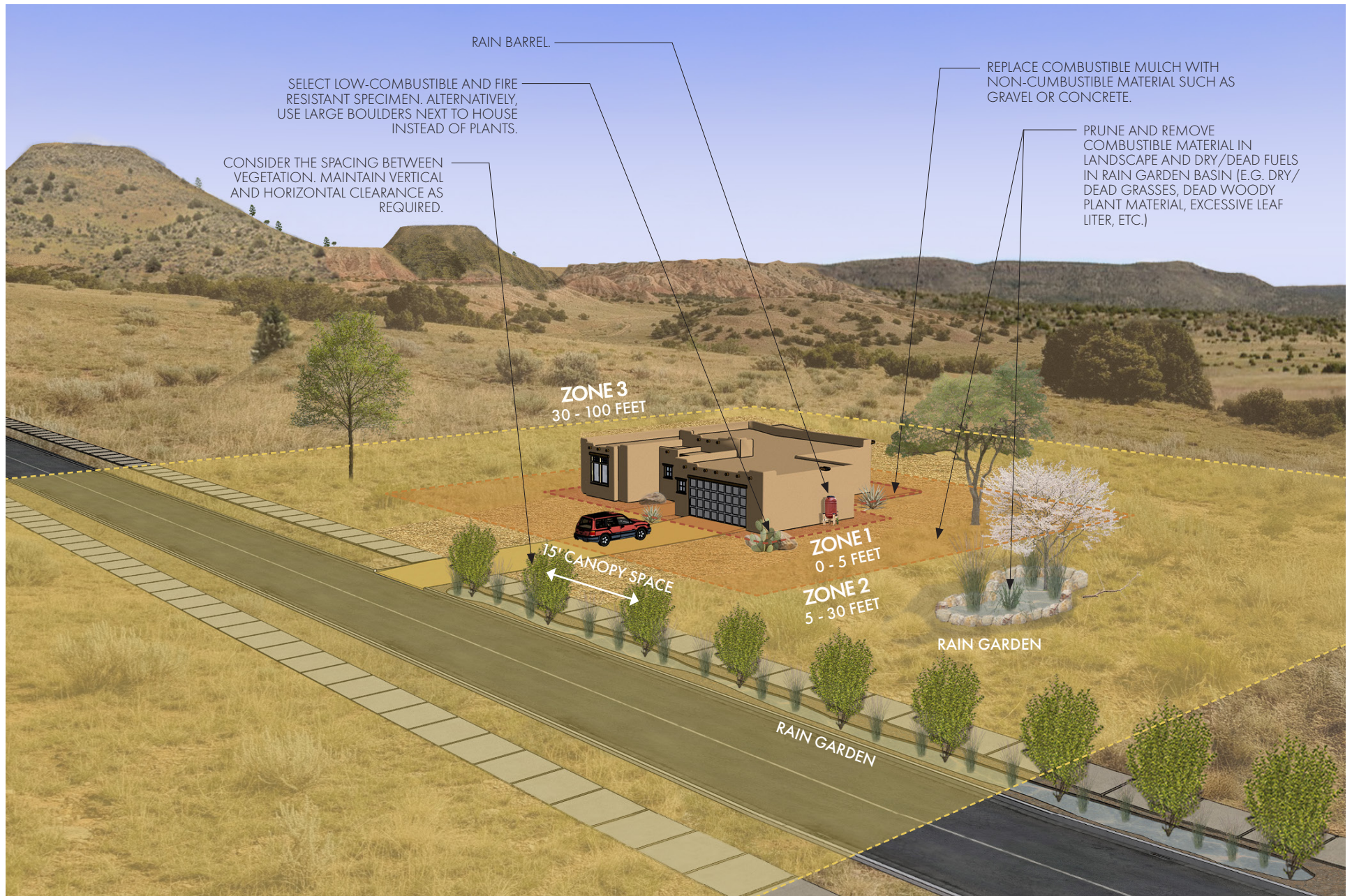

This page, next page: diagram demonstrating wildfire defensible space BMP's for a typical residence in Santa Fe County.

DEFINITIONS

TERM	DEFINITIONS
Bankfull	The initial elevation on the bank of a channel where flooding begins. Bankfull is often seen as a distinct geomorphological level/terrace in stable channels, but can be less obvious in unstable/degrading systems.
Bioremediation	The selection of specific living systems to mitigate various pollutants including those negatively impacting water quality. Living systems could include plants (phyto-), soil organisms in the rootzone (rhyzo-), or other beneficial organisms. Processes by which remediation can occur include volatilization, absorption, adsorption, stabilization, degradation, etc.
Detention Basin	A stormwater catchment basin intended to capture large volumes of runoff from expansive impervious areas. Detention basins are often devoid of vegetation, have cobble mulch as the only soil amendment, and have fenced perimeters to prevent drowning. While these basins capture and help percolate large volumes of stormwater, they lack habitat and water filtration value which is why detention basins are typically not considered GSI.
First Flush	The initial flow of stormwater during a precipitation event which might have highly concentrated pollutants that have accumulated on impervious surfaces between storms.
Green Infrastructure	Constructed features that use living, natural systems to provide environmental services such as pollution remediation, cooling, etc. Green infrastructure is used as an alternative to conventional "grey" infrastructure such as wastewater treatment plants, concrete piping, etc. Examples of GI include green roofs, urban forestry, constructed wetlands, etc.
Green Stormwater Infrastructure	Green infrastructure specifically intended to address water quality and quantity issues resulting from stormwater runoff. A central tenet of GSI is to slow, capture, and treat stormwater runoff close to where it falls as precipitation. Examples include rain gardens, bioretention basins, bioswales, etc.
Infiltration Rate and Capacity	Infiltration is the movement of water through the surface of the soil. The rate of infiltration is usually measured in inches/hour and will differ depending on texture (e.g. proportion of clay, silt, sand), disturbance (e.g. compaction), etc. Infiltration capacity is the maximum rate that water will enter the soil surface before stormwater runoff occurs.
Headcut	A rapid change in elevation or knickpoint leading to a steeper or vertical edge feeding a channel (e.g. rill or gully). If left untreated, a headcut will migrate upslope, further eroding soil as it moves.
Non-point Source Stormwater Pollution	Pollutants that end up in water resources without a known origin, making remediation at the pollution source more challenging.
Rill	A small eroding channel common on disturbed soils such as road cuts, recently plowed fields, etc.
Sheet flow	A condition of flooding where there is moving water, but no identifiable channel. Sheet flow allows for a more even distribution of water resources and nutrients across the land surface compared to channels.
Urban Heat Island Effect	A metropolitan area that is significantly warmer than surrounding rural areas because of high-density development including heat retaining impervious surfaces (e.g. roads, parking lots, buildings, artificial turf, etc.). Note that degraded, bare soil in more rural areas might also result in warmer surface temperatures compared to areas with healthy plant cover and higher soil moisture content.

REFERENCES AND RESOURCES

1. U.S. Census Bureau, 2024 Santa Fe County, New Mexico Census Bureau Profile, https://data.census.gov/profile/Santa_Fe_County,_New_Mexico?g=050XX00US35049, Accessed on August 22, 2025 2.
2. U.S. Geological Survey, 2019, The StreamStats program, online at <https://streamstats.usgs.gov/ss/>, Accessed on August 22, 2025
3. Zeedyk, B. and V. Clothier. 2009. Let the Water do the Work: Induced Meandering, an Evolving Method for Restoring Incised Channels. The Quivira Coalition, Santa Fe, NM, USA, pp. 239. <https://quiviracoalition.org/product/let-the-water-do-the-work-induced-meandering-and-evolving-method-for-restoring-incised-channels/>
4. Weather Underground. (2025). Weather History for Santa Fe, NM. <https://www.wunderground.com/weather/us/nm/santa-fe>, Accessed on August 22, 2025
5. National Oceanic and Atmospheric Administration (NOAA), National Centers for Environmental Information, Santa Fe, NM, <https://www.ncei.noaa.gov/access/past-weather/36.070949,-106.4633548,35.570949,-105.9633548>, Accessed on August 22, 2025
6. Sponholtz, C. and A. Anderson. 2010. Erosion control field guide. Quivira Coalition. <https://quiviracoalition.org/product/erosion-control-field-guide/>
7. Quivira Coalition Video Series with Erosion Control Structures
 - a. One Rock Dam: <https://www.youtube.com/watch?v=qvrp6qRvYbo&list=PLFHRwsJneIf746YZ-NbdalHtkoRXBXpC&index=5>
 - b. Rock Rundown: <https://www.youtube.com/watch?v=lclD5HlplfO&list=PLFHRwsJneIf746YZ-NbdalHtkoRXBXpC&index=3>
 - c. Media Luna: <https://www.youtube.com/watch?v=W1JAv9wca1E&list=PLFHRwsJneIf746YZ-NbdalHtkoRXBXpC&index=4>
8. Grabar, Henry. Paved Paradise: How Parking Explains the World. Penguin Press, 2023.
9. Environmental Protection Agency (EPA). Permeable Pavements. Stormwater Best Management Practice EPA-832-F-21-031W; Office of Water: Washington, DC, USA, 2021.
10. Zeedyk, B. 2006. Water Harvesting from Low-Standard Rural Roads. The Quivira Coalition, Zeedyk Ecological Consulting, LLC, the Rio Puerco Management Committee—Watershed Initiative, and the New Mexico Environment Department—Surface Water Quality Bureau. pp. 47. <https://quiviracoalition.org/product/good-road/>
11. Soil Survey Staff, Natural Resources Conservation Service, United States Department of Agriculture. Web Soil Survey. Available online at <https://websoilsurvey.nrcs.usda.gov/>. Accessed on August 22, 2025
12. Hsieh, C. and A.P. Davis. 2005. Evaluation and optimization of bioretention media for treatment of urban storm water runoff. Journal of Environmental Engineering, 131 (11) pp. 1,521-1531.: <https://citeseerx.ist.psu.edu/document?repid=rep1&type=pdf&doi=d23908f463b908ec0ce34bf0eeb39ea334757afc>
13. Urban, James. Bringing Order to the Technical Dysfunction within the Urban Forest. Journal of Arboriculture 18 (2), March 1992.: <https://joa.isa-arbor.com/request.asp?JournalID=1&ArticleID=2490&Type=2>
14. Kauffman, A. T., and Stropki, C. L. Green stormwater infrastructure in a semi-arid climate: The influence of rain gardens on soil moisture over seven years. The Western Planner. November 7, 2022: <https://www.westernplanner.org/2022/2022/10/22/green-stormwater-infrastructure-in-a-semi-arid-climate-the-influence-of-rain-gardens-on-soil-moisture-over-seven-years>
15. Famulari, Stevie. Phytoremediation Plant Database: <https://www.steviefamulari.net/phytoremediation-plant-database>, Accessed on August 22, 2025
16. Kennen, K., and Kirkwood, N. 2015. Phyto: Principles and resources for site remediation and landscape design. Routledge, London

REFERENCES

REFERENCES AND RESOURCES

17. Wolf, K. L. 2009 (August). Trees mean business--City trees and the retail streetscape. Main Street News 263 (1-9).: https://www.naturewithin.info/CityBiz/MainStreetNews_Aug09_Trees.pdf
18. Vargas, K.E.; McPherson, E.G.; Simpson, J.R.; Peper, P.J.; Gardner, S.L.; Xiao, Q. 2006. City of Albuquerque, New Mexico, Municipal Forest Resource Analysis. Center for Urban Forest Research, Pacific Southwest Research Station, U.S. Department of Agriculture Forest Service. 55 p.: https://www.fs.usda.gov/psw/topics/urban_forestry/products/cufr_674_ABQ_MFRA_for_web.pdf
19. Bassuk, N., Curtis, D. F., Marranca, B. Z., & Barb, N. (2009). Recommended Urban Trees: Site Assessment and Tree Selection for Stress Tolerance. Ithaca, New York: Urban Horticulture Institution, Cornell University. Online: Cornell University. Woody Plants Database: <https://woodyplants.cals.cornell.edu/plant/search>, Accessed on August 22, 2025
20. NM Administration Code §19.25.12.11 -Design of a dam (2010)
21. U.S. Environmental Protection Agency. (2015). Estimating Predevelopment Hydrology for Urbanized Areas in New Mexico (EPA Publication No. 832-R-15-009). Prepared by TETRA TECH, Inc., for the EPA Office of Wastewater Management.
22. New Mexico Department of Transportation. 2024. NMDOT GSI Maintenance Field Guide. https://www.dot.nm.gov/wp-content/uploads/2024/07/2024-05-23-GSI-Maintenance-Field-Guide_FINAL-FOR-WEB.pdf
23. New Mexico Energy, Minerals and Natural Resources Department. 2021-2022. Protecting your home from wildfire. <https://www.emnrd.nm.gov/sfd/fire-prevention-programs/protecting-your-home-from-wildfire/>
24. Wildland Fires Ready, Set, Go. 2018. Ready, Set, Go! for the Seasonal Resident and Property Owner. https://www.wildlandfirersg.org/s/iafc2/wildland-fire-preparedness-for-seasonal-residents-and-property-owners-MCVDXMKPH4RFCPBE7YLLW6YEI3FGM?language=en_US
25. National Fire Protection Agency. 2017. Reducing Wildfire Risks in the Home Ignition Zone. <https://www.nfpa.org/education-and-research/wildfire-preparing-homes-for-wildfire>

GSI Deep Dive - Urban Hydrology

1. Schoener, Gerhard. "Urban runoff in the US Southwest: Importance of impervious surfaces for small-storm hydrology." *Journal of Hydrologic Engineering* 23.2 (2018): 05017033.
2. Xiao, Qingfu, et al. "Hydrologic processes at the urban residential scale." *Hydrological Processes: An International Journal* 21.16 (2007): 2174-2188.
3. Mikkelsen, Peter Steen, et al. "Pollution from urban stormwater infiltration." *Water Science and Technology* 29.1-2 (1994): 293-302.
4. Glass, Charles, and Saquiequois Bissouma. "Evaluation of a parking lot bioretention cell for removal of stormwater pollutants." *WIT Transactions on Ecology and the Environment* 81 (2005).
5. MacDonald, Glen M. "Water, climate change, and sustainability in the southwest." *Proceedings of the National Academy of Sciences* 107.50 (2010): 21256-21262.
6. Wilson, John L., and Huade Guan. "Mountain-block hydrology and mountain-front recharge." *Groundwater recharge in a desert environment: The Southwestern United States* 9 (2004): 113-137.
7. Walsh, Christopher J., Tim D. Fletcher, and Anthony R. Ladson. "Stream restoration in urban catchments through redesigning stormwater systems: looking to the catchment to save the stream." *Journal of the North American Benthological Society* 24.3 (2005): 690-705.

GSI Deep Dive - Urban Hydrology

8. Burns, Matthew J., et al. "Hydrologic shortcomings of conventional urban stormwater management and opportunities for reform." *Landscape and urban planning* 105.3 (2012): 230-240.
9. MacDonald, Glen M. "Water, climate change, and sustainability in the southwest." *Proceedings of the National Academy of Sciences* 107.50 (2010): 21256-21262.
10. Dunkerley, David L., and Kate J. Brown. "Desert soils." *Arid zone geomorphology: process, form and change in drylands* (1997): 55-68.

GSI Deep Dive - Urban Stormwater Quality

1. Erickson, Andrew J., Peter T. Weiss, and John S. Gulliver. "Optimizing stormwater treatment practices." *A Handbook of Assessment and Maintenance* 1.1 (2013): 1-337.
2. Kuehler, Eric, Jon Hathaway, and Andrew Tirpak. "Quantifying the benefits of urban forest systems as a component of the green infrastructure stormwater treatment network." *Ecohydrology* 10.3 (2017): e1813.
3. Burns, Matthew J., et al. "Hydrologic shortcomings of conventional urban stormwater management and opportunities for reform." *Landscape and urban planning* 105.3 (2012): 230-240.
4. Azah, Edmund, Hwidong Kim, and Timothy Townsend. "Assessment of direct exposure and leaching risk from PAHs in roadway and stormwater system residuals." *Science of The Total Environment* 609 (2017): 58-67.
5. Sirova, Viktoriya. "Urban stormwater management: treatment of heavy metals and polycyclic aromatic hydrocarbons with bioretention and permeable pavement technologies." (2015).
6. Shedivy, Ryan F., et al. "Leaching characteristics of recycled asphalt pavement used as unbound road base." *University of Wisconsin System Solid Waste Research Program-Student Project Report* (2012).
7. Mikkelsen, Peter Steen, et al. "Pollution from urban stormwater infiltration." *Water Science and Technology* 29.1-2 (1994): 293-302.
8. Cho, Kyung Hwa, et al. "Modeling seasonal variability of fecal coliform in natural surface waters using the modified SWAT." *Journal of Hydrology* 535 (2016): 377-385.
9. Walsh, Christopher J., Tim D. Fletcher, and Anthony R. Ladson. "Stream restoration in urban catchments through redesigning stormwater systems: looking to the catchment to save the stream." *Journal of the North American Benthological Society* 24.3 (2005): 690-705.
10. Papoulias, Diana M., et al. "Health and histopathological evaluation of Rio Grande silvery minnow from the Rio Grande, New Mexico." *USGS Columbia Environmental Research Center, Columbia, Missouri* (2009).
11. Storms, Erik F., et al. *Summary of urban stormwater quality in Albuquerque, New Mexico, 2003-12*. No. 2015-5006. US Geological Survey, 2015. [??](#)

GSI Deep Dive - Urban Forestry

1. Kuehler, Eric, Jon Hathaway, and Andrew Tirpak. "Quantifying the benefits of urban forest systems as a component of the green infrastructure stormwater treatment network." *Ecohydrology* 10.3 (2017): e1813. Chini, Christopher M., et al. "The green experiment: Cities, green stormwater infrastructure, and sustainability." *Sustainability* 9.1 (2017): 105.
2. Nadezhkina, Nadezhda, et al. "Trees never rest: the multiple facets of hydraulic redistribution." *Ecohydrology* 3.4 (2010): 431-444. *The Ecohydrologic Significance of Hydraulic Redistribution in a Semiarid Savanna*. Russell Scott, William Cable, and Kevin Hutine.

REFERENCES

GSI Deep Dive - Urban Forestry

1. Kuehler, Eric, Jon Hathaway, and Andrew Tirpak. "Quantifying the benefits of urban forest systems as a component of the green infrastructure stormwater treatment network." *Ecohydrology* 10.3 (2017): e1813.
2. Scott, Russell L., William L. Cable, and Kevin R. Hultine. "The ecohydrologic significance of hydraulic redistribution in a semiarid savanna." *Water Resources Research* 44.2 (2008).
3. Elliott, A. H., and Sam A. Trowsdale. "A review of models for low impact urban stormwater drainage." *Environmental modelling & software* 22.3 (2007): 394-405.
4. Suppakittpaisarn, Pongsakorn, Xiangrong Jiang, and William C. Sullivan. "Green infrastructure, green stormwater infrastructure, and human health: A review." *Current Landscape Ecology Reports* 2 (2017): 96-110.
5. Aanderud, Zachary T., and James H. Richards. "Hydraulic redistribution may stimulate decomposition." *Biogeochemistry* 95.2 (2009): 323-333.
6. Nieuwenhuijsen, Mark J. "Green infrastructure and health." *Annual Review of Public Health* 42.1 (2021): 317-328.
7. Burgess, Stephen SO. "Can hydraulic redistribution put bread on our table?" *Plant and Soil* 341.1 (2011): 25-29. Hydraulic Redistribution may Stimulate Decomposition. Zachary T. Aanderud and James H. Richards. *Biogeochemistry* (2009) 95: 323-333.

GSI Deep Dive - Phytoremediation

1. Peer, Wendy Ann, et al. "Phytoremediation and hyperaccumulator plants." *Molecular biology of metal homeostasis and detoxification: from microbes to man*. Berlin, Heidelberg: Springer Berlin Heidelberg, 2005. 299-340.
2. Read, Jennifer, et al. "Plant traits that enhance pollutant removal from stormwater in biofiltration systems." *International Journal of Phytoremediation* 12.1 (2009): 34-53.
3. Rycewicz-Borecki, Malgorzata, Joan E. McLean, and R. Ryan Dupont. "Bioaccumulation of copper, lead, and zinc in six macrophyte species grown in simulated stormwater bioretention systems." *Journal of Environmental Management* 166 (2016): 267-275.4.
4. Ndimele, P. E. "A review on the phytoremediation of petroleum hydrocarbon." *Pakistan journal of biological sciences: PJBS* 13.15 (2010): 715-722.
5. Aprill, Wayne, and Ronald C. Sims. "Evaluation of the use of prairie grasses for stimulating polycyclic aromatic hydrocarbon treatment in soil." *Chemosphere* 20.1-2 (1990): 253-265.

GSI Deep Dive - Mycoremediation

1. Geoff Gadd. Fungi in Bioremediation. *Bioremediation Potential of White Rot Fungi*. C. Adinarayana Reddy and Zacharia Mathew. Cambridge University Press 2001 52-78.
2. Patricia J. Harvey and Christopher F. Thurston. *The Biochemistry of Ligninolytic Fungi*. Cambridge University Press 2001 27-51
3. Bezalel, Lea, Yitzhak Hadar, and Carl E. Cerniglia. "Mineralization of polycyclic aromatic hydrocarbons by the white rot fungus *Pleurotus ostreatus*." *Applied and environmental microbiology* 62.1 (1996): 292-295.
4. Haritash, A. K., and C. P. Kaushik. "Biodegradation aspects of polycyclic aromatic hydrocarbons (PAHs): a review." *Journal of hazardous materials* 169.1-3 (2009): 1-15.
5. Márquez-Rocha, Facundo J., Vanessa Z. Hernández-Rodríguez, and Rafael Vázquez-Duhalt. "Biodegradation of soil-adsorbed polycyclic aromatic hydrocarbons by the white rot fungus *Pleurotus ostreatus*." *Biotechnology letters* 22.6 (2000): 469-472.

GSI Deep Dive - Mycoremediation

6. In Der Wiesche, C., R. Martens, and F. Zadrazil. "The effect of interaction between white-rot fungi and indigenous microorganisms on degradation of polycyclic aromatic hydrocarbons in soil." *Water, Air and Soil Pollution: Focus* 3.3 (2003): 73-79.
7. Li, Xuanzhen, et al. "Dissipation of polycyclic aromatic hydrocarbons (PAHs) in soil microcosms amended with mushroom cultivation substrate." *Soil Biology and Biochemistry* 47 (2012): 191-197. 8. Pozdnyakova, Natalia N., Svetlana V. Nikiforova, and Olga V. Turkovskaya. "Influence of PAHs on ligninolytic enzymes of the fungus *Pleurotus ostreatus* D1." *Central European Journal of Biology* 5.1 (2010): 83-94.
9. Bogan, Bill W., et al. "Extent of humification of anthracene, fluoranthene, and benzo [] pyrene by *Pleurotus ostreatus* during growth in PAH-contaminated soils." *Letters in Applied Microbiology* 28.4 (1999): 250-254.
10. Márquez-Rocha, Facundo J., Vanessa Z. Hernández-Rodríguez, and Rafael Vázquez-Duhalt. "Biodegradation of soil-adsorbed polycyclic aromatic hydrocarbons by the white rot fungus *Pleurotus ostreatus*." *Biotechnology Letters* 22.6 (2000): 469-472.
11. Haritash, A. K., and C. P. Kaushik. "Biodegradation aspects of polycyclic aromatic hydrocarbons (PAHs): a review." *Journal of hazardous materials* 169.1-3 (2009): 1-15.
12. Stainer, R. Y., and L. N. Ornston. "The β -ketoacid pathway." *Advances in microbial physiology* 9 (1973): 89-151
13. Wells, Tyrone, and Arthur J. Ragauskas. "Biotechnological opportunities with the β -ketoacid pathway." *Trends in biotechnology* 30.12 (2012): 627-637.
14. Bugg, Timothy DH, et al. "Pathways for degradation of lignin in bacteria and fungi." *Natural product reports* 28.12 (2011): 1883-1896.
15. Lammers, Peter J., et al. "The glyoxylate cycle in an arbuscular mycorrhizal fungus. Carbon flux and gene expression." *Plant Physiology* 127.3 (2001): 1287-1298.
16. Beevers, Harry. "The role of the glyoxylate cycle." *Lipids: structure and function*. Academic Press, 1980. 117-130.

GSI Deep Dive - Human Health

1. Gaekwad, Jason S., et al. "A meta-analysis of emotional evidence for the biophilia hypothesis and implications for biophilic design." *Frontiers in Psychology* 13 (2022): 750245.
2. Gullone, Eleonora. "The biophilia hypothesis and life in the 21st century: increasing mental health or increasing pathology?" *Journal of happiness studies* 1.3 (2000): 293-322.
3. Coutts, Christopher, and Micah Hahn. "Green infrastructure, ecosystem services, and human health." *International journal of environmental research and public health* 12.8 (2015): 9768-9798.
4. Venkataramanan, Vidya, et al. "A systematic review of the human health and social well-being outcomes of green infrastructure for stormwater and flood management." *Journal of environmental management* 246 (2019): 868-880.
5. Nieuwenhuijsen, Mark J. "Green infrastructure and health." *Annual Review of Public Health* 42.1 (2021): 317-328.
6. Hewitt, C. Nick, Kirsti Ashworth, and A. Rob MacKenzie. "Using green infrastructure to improve urban air quality (GI4AQ)." *Ambio* 49.1 (2020): 62-73.
7. Balany, Fatma, et al. "Green infrastructure as an urban heat island mitigation strategy—a review." *Water* 12.12 (2020): 3577.
8. Shepley, Mardelle, et al. "The impact of green space on violent crime in urban environments: an evidence synthesis." *International journal of environmental research and public health* 16.24 (2019): 5119.
9. Burley, Blair Alexandra. "Green infrastructure and violence: Do new street trees mitigate violent crime?" *Health & place* 54 (2018): 43-49.

In tribute to and in honor of water.

El Agua Es Vida!

- The Raincatcher Inc. Team and Southwest Urban Hydrology

